

DRAFT

# PRELIMINARY ENGINEERING REPORT

Rifle Range Road WWTP

Rehabilitation and Expansion

MPW PROJECT NO. STR 1608

B&V PROJECT NO. 192352

PREPARED FOR

Mount Pleasant Waterworks



17 SEPTEMBER 2017



## Table of Contents

<b>1.0</b>	<b>Project Description.....</b>	<b>1-1</b>
1.1	Contact Information.....	1-3
1.2	Service Area.....	1-4
1.2.1	Future Land Use and Population Projections.....	1-4
1.2.2	Future Flow Projections.....	1-5
1.3	Project Schedule .....	1-5
<b>2.0</b>	<b>Project Requirements.....</b>	<b>2-1</b>
2.1	Receiving Waters .....	2-1
2.2	Construction Contract.....	2-1
2.3	Project Datum.....	2-1
2.4	Local Flood Levels .....	2-1
2.5	Sources of Utilities.....	2-2
2.6	Permitting.....	2-2
2.7	Reliability Classification.....	2-2
2.8	Alternatives Evaluation.....	2-7
2.8.1	Reuse.....	2-7
2.8.2	Groundwater Recharge.....	2-7
2.8.3	Connection to Another Wastewater Treatment Plant.....	2-7
2.8.4	Use of Land Application.....	2-8
2.8.5	Alternatives Selection .....	2-8
<b>3.0</b>	<b>Existing Facilities .....</b>	<b>3-1</b>
3.1	Influent Screening.....	3-1
3.2	Vortex Grit Chambers.....	3-2
3.3	Anoxic Selector Basins.....	3-2
3.4	Oxidation Ditches.....	3-2
3.5	Recirculation Pumping .....	3-4
3.6	Secondary Clarifiers.....	3-4
3.7	RAS Pumping .....	3-5
3.8	WAS Pumping.....	3-6
3.9	Disinfection.....	3-6
3.10	Effluent Pumping .....	3-7
3.11	Sludge Storage.....	3-7
3.12	Dewatering .....	3-8
3.13	Septage Receiving Facility .....	3-9
3.14	Hydraulic Profile Information .....	3-9
<b>4.0</b>	<b>Project Design Criteria .....</b>	<b>4-1</b>
4.1	Wastewater Characteristics.....	4-1
4.2	Plant Process Capacity.....	4-3

4.3	Hydraulic Capacity .....	4-3
4.4	Permit Limits .....	4-5
<b>5.0</b>	<b>Facility Design Criteria.....</b>	<b>5-1</b>
5.1	Wastewater Treatment Plant Improvements .....	5-1
5.2	Influent Line .....	5-2
5.3	Influent Pumping Station.....	5-2
5.4	Influent Pump Station Motor Control Center .....	5-4
5.5	Headworks.....	5-4
	5.5.1 Mechanical Screening.....	5-5
	5.5.2 Manual Screening.....	5-6
	5.5.3 Grit Removal .....	5-6
5.6	Septage and Vacuum Truck Receiving Facility .....	5-8
5.7	Equalization Basins.....	5-8
5.8	Anoxic Distribution Box .....	5-10
5.9	Anoxic/Aeration Basins .....	5-11
5.10	Aeration Blowers .....	5-14
5.11	Blower Room .....	5-16
5.12	Secondary Clarifiers.....	5-16
	5.12.1 Secondary Clarifier Splitter Box.....	5-17
5.13	RAS Pumping .....	5-18
5.14	WAS Pumping.....	5-18
5.15	Disinfection.....	5-19
	5.15.1 Chlorine Contact Basins .....	5-19
	5.15.2 Sodium Hypochlorite Storage and Feed system.....	5-20
5.16	Effluent Diffuser .....	5-25
5.17	Sludge Storage.....	5-26
5.18	Dewatering Facility (New).....	5-28
	5.18.1 Polymer Storage and Feed system.....	5-31
5.19	Storage Facility (Existing Dewatering Building).....	5-34
5.20	Site Work And Piping .....	5-34
	5.20.1 General .....	5-34
	5.20.2 Facility and Piping Additions .....	5-34
	5.20.3 Tree Mitigation.....	5-35
5.21	Odor Control .....	5-35
5.22	Instrumentation and Control.....	5-36
5.23	Power Distribution.....	5-37
5.24	Standby Power .....	5-37
5.25	Control Building One .....	5-37
5.26	Control Building Two .....	5-38
5.27	Power System Studies.....	5-38

5.28	Lighting protection, Surge Protection Devices and TVSS.....	5-39
5.29	Reuse Plant Service Water .....	5-39
5.30	Plant Drain Pumping System .....	5-41
5.30.1	Plant Drain Pump Station #1 .....	5-41
5.30.2	Plant Drain Pump Station #2 .....	5-42
5.30.3	Plant Drain Pump Station #3 .....	5-42
5.30.4	Existing Dewatering Building Pump Station .....	5-43
5.31	Effluent Force main Restraint.....	5-43
5.31.1	General Background .....	5-43
5.31.2	Options to Mitigate Unrestrained Pipeline Joints.....	5-43
5.32	Existing Facilities Demolition and Decommissioning.....	5-43
5.32.1	Structure Demolition.....	5-43
<b>6.0</b>	<b>Supplemental Memoranda.....</b>	<b>6-1</b>
6.1	Liquid Process Flow Diagram .....	6-2
6.2	Solids Process Flow Diagram .....	6-3
6.3	Project Drawings.....	6-4
6.4	MPW Service Area Map .....	6-5
6.5	Effluent Discharge Forcemain Map .....	6-6
6.6	United States Geological Survey (USGS) Map for Discharge Outfall .....	6-7
6.7	RRRWTP One Mile Radius Topographic Map .....	6-8
6.8	MPW 20-Year Land Planning Area Map .....	6-9
6.9	MPW 20-Year Land Use Map.....	6-10
6.10	MPW 20-Year Population Growth Projections .....	6-11
6.11	MPW 20-Year Flow Projections .....	6-12

**LIST OF TABLES**

Table 1-1	Influent Flow Projections .....	1-5
Table 2-1	Reliability Classification III .....	2-3
Table 3-1	Existing Facilities .....	3-1
Table 3-2	Influent Screens.....	3-1
Table 3-3	Vortex Grit Chamber.....	3-2
Table 3-4	Anoxic Selector Basin.....	3-2
Table 3-5	Oxidation Ditches.....	3-3
Table 3-6	Oxidation Ditch Aeration .....	3-3
Table 3-7	Recirculation Pumping .....	3-4
Table 3-8	Secondary Clarifiers.....	3-4
Table 3-9	RAS Pumping .....	3-5
Table 3-10	WAS Pumping.....	3-6
Table 3-11	Disinfection.....	3-6
Table 3-12	Effluent Pumping .....	3-7



Table 3-13	Sludge Storage.....	3-8
Table 3-14	Belt Filter Press.....	3-8
Table 4-1	Design Flows For 9.2 MGD Annual Average Flow .....	4-1
Table 4-2	RRRWTP Wastewater Characteristics for 9.2 MGD Plant Capacity .....	4-2
Table 4-3	Unit Process Design Capacity for 10.6 MGD Maximum Month Flow .....	4-3
Table 4-4	Hydraulic Design Flows.....	4-3
Table 4-5	Hydraulic Profile Flow Conditions.....	4-5
Table 4-6	Existing and Buildout WAS Production Rates.....	4-5
Table 4-7	Rifle Range Road WWTP Current and Draft NPDES Permit Requirements .....	4-6
Table 5-1	Mechanically Cleaned Multi-Rake Screen .....	5-2
Table 5-2	Influent Pumping Station.....	5-3
Table 5-3	Mechanical Screens .....	5-5
Table 5-4	Manual Bar Rack.....	5-6
Table 5-5	Grit Removal System .....	5-7
Table 5-6	Equalization Basins.....	5-10
Table 5-7	Anoxic Distribution Box .....	5-11
Table 5-8	Anoxic Basins.....	5-12
Table 5-9	Aeration Basins.....	5-12
Table 5-10	Diffused Aeration System .....	5-13
Table 5-11	Mixed Liquor Return Pumps .....	5-14
Table 5-12	Aeration Blowers Design Criteria .....	5-15
Table 5-13	Secondary Clarifiers.....	5-17
Table 5-14	RAS Pumping .....	5-18
Table 5-15	WAS Pumping.....	5-18
Table 5-16	Disinfection.....	5-19
Table 5-17	Sodium Hypochlorite Disinfection System Design Information.....	5-21
Table 5-18	Effluent Diffuser .....	5-26
Table 5-19	Sludge Storage.....	5-27
Table 5-20	WAS Production Versus Flow .....	5-29
Table 5-21	Belt Filter Press Design Parameters.....	5-29
Table 5-22	Belt Filter Press Capacity Versus Flow .....	5-30
Table 5-23	Truck Loading Times Versus Flow .....	5-31
Table 5-24	Dewatering Polymer System Design Information.....	5-32
Table 5-25	Plant Service Water Demands .....	5-40
Table 5-26	Plant Service Water Pumps.....	5-40
Table 5-27	Plant Drain Pump Station #1 .....	5-41
Table 5-28	Plant Drain Pump Station #3 .....	5-42
Table 5-29	Structure Demolition.....	5-44

## LIST OF FIGURES

Figure 1-1	Plant Location.....	1-2
Figure 1-2	Existing Liquids and Solids Treatment Process Train.....	1-3
Figure 1-3	Mount Pleasant Waterworks Service Area Map.....	1-4
Figure 5-1	Center Flow Band Screen Flow Path.....	5-5

## 1.0 Project Description

The Mount Pleasant Waterworks (MPW) Rifle Range Road Wastewater Treatment Plant (RRRWWTP) is located 2 miles northeast of Mount Pleasant and approximately 1 mile southeast of the intersection of Highway 17 and Interstate 526, as shown in Figure 1-1. RRRWWTP is permitted to treat 6.0 million gallons per day (mgd) annual average (AA) flow under the current NPDES permit. The existing liquids process train is made up of headworks, anoxic basins, oxidation ditches, final clarifiers, and chlorine contact basins. Effluent is pumped through a force main combines with effluent from MPW Center Street Wastewater Treatment Plant, Reverse Osmosis Plant number 1 and Reverse Osmosis Plant number 3 and discharges into Charleston Harbor. Solids are processed by dewatering with a belt filter press followed by landfill disposal.

Following an extensive, system-wide alternatives evaluation, it is proposed that the RRRWWTP treatment capacity be expanded from 6.9 mgd maximum month (MM) (6 mgd AA) to 10.6 mgd MM (9.2 mgd AA). The upgrade will include the following facility improvements:

- A new influent force main to convey flow to a new influent pump station.
- The new influent pump station will include one coarse screen and a duplex wetwell to convey flow to a new headworks facility.
- The construction of new septage receiving and odor control facility.
- The headworks facility will include fine screening, grit removal and flow metering.
- The two existing carrousel structures will be converted to flow equalization structures for use as wet weather tanks.
- The two existing anoxic selector basins will be converted to sludge storage.
- A new anoxic distribution structure and four new anoxic/aeration basins will be constructed.
- The existing chlorine contact basin will be expanded to provide additional contact time.
- A new blower building will be constructed to house the new aeration blowers and new air compressors, which will provide compressed air mixing to the new anoxic basins.
- A new dewatering building will be constructed to house two new belt filter presses.
- A new central power distribution center will be constructed to connect to the two existing engine generators and provide emergency backup power for the facility.
- The existing dewatering building will be converted to an operation facility and storage area.
- A new air compressor enclosure will be constructed to provide compressed air mixing to the new anoxic basins.



**Figure 1-1 Plant Location**

The existing liquid process train consists of mechanical screens, grit removal, anoxic selector, oxidation ditch, secondary clarification, chlorine contact basin, and effluent pumping as shown in Figure 1-2 below. The existing solids process train consists of solids storage/decanting basins, dewatering, and landfilling of solids, also shown below.

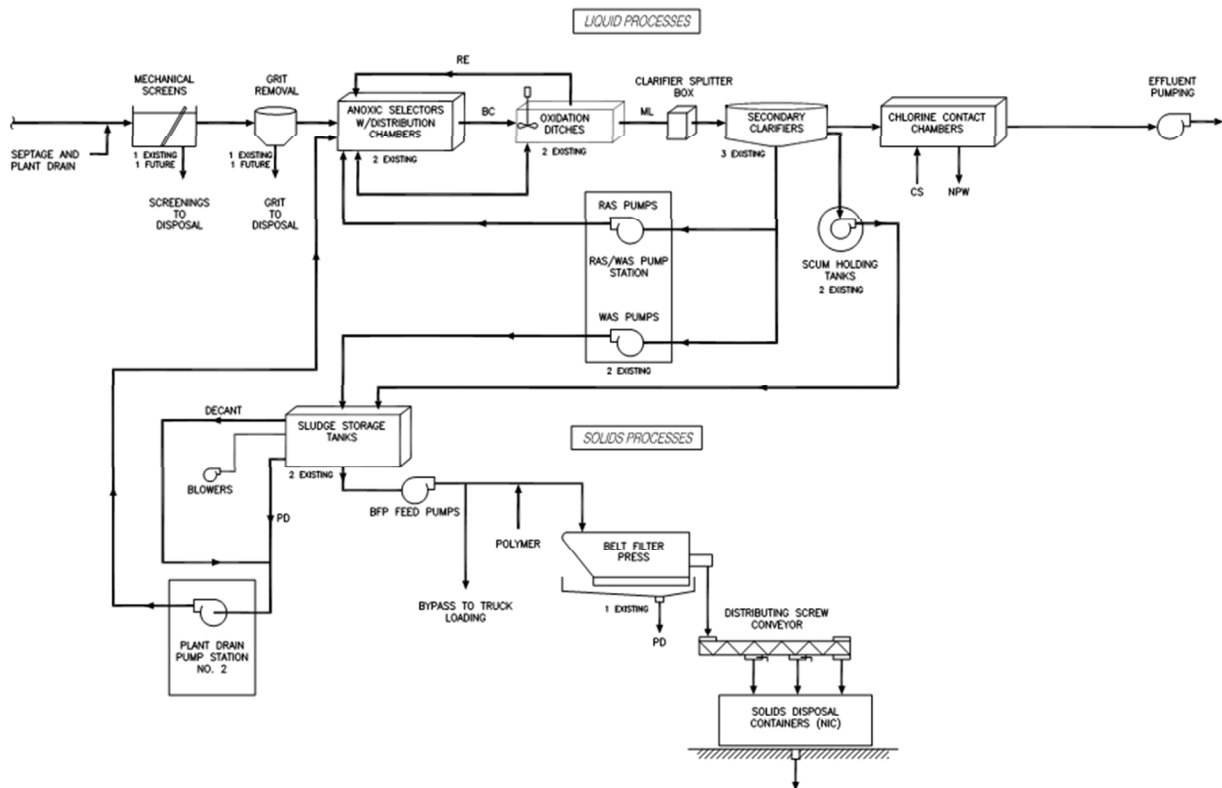

Figure 1-2 Existing Liquids and Solids Treatment Process Train

### 1.1 CONTACT INFORMATION

Owner: Mount Pleasant Waterworks  
 1619 Rifle Range Road  
 Mount Pleasant, SC 29464  
 (843) 971-7504  
 Contact: Tom Wright

Engineer: Black & Veatch Corporation  
 550 King Street  
 Charleston, SC 29403  
 (843) 266-0667  
 Contact: Jeff Wells, P.E., Project Manager

Contractor: Garney Construction  
 4510 Rivers Avenue  
 North Charleston, SC 29405  
 (407) 395-7488  
 Contact: Matt Reaves



## 1.2 SERVICE AREA

Mount Pleasant Waterworks has a service population of 87,710. The existing wastewater service area covers approximately 76 square miles with 160 pump stations and 1.96 million feet of gravity wastewater piping. The service area for RRRWWTP is primarily a mixture of residential and commercial customers. The area that RRRWWTP serves is shown below in Figure 1-3.

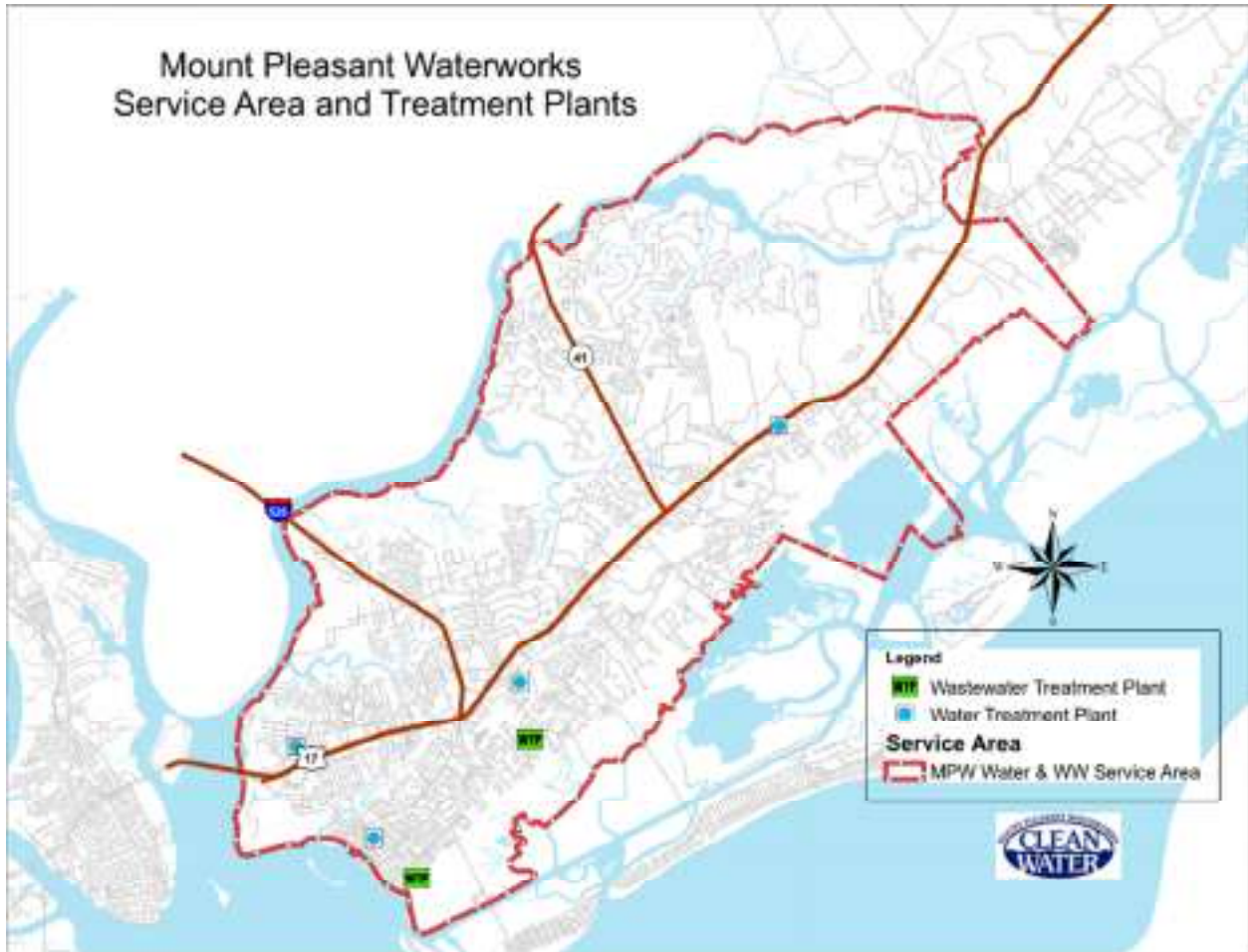

Figure 1-3 Mount Pleasant Waterworks Service Area Map

### 1.2.1 Future Land Use and Population Projections

Future land growth projections were provided for the Town of Mount Pleasant as part of the 2010 Master Plan and included in a 2014 report by CDM, "*Water Demand and Wastewater Flow Factors and Future REU Projections.*" Future land use data was provided in the *Town of Mount Pleasant 2009-2019 Comprehensive Plan*. These growth projections were updated in *The 2014 Comprehensive Plan Update* to indicate additional residential equivalency units (REU) and planning areas. MPW's 20-year land planning service map can be seen in Section 6.0. *The 2014 Comprehensive Plan Update* also updated the growth projections concerning future land use. MPW's future land use and land availability map can also be seen in Section 6.0. It was assumed

that all developed land would be built-out to the maximum use specified in *The 2014 Comprehensive Plan Update*.<sup>1</sup>

The future population growth projections for the Town of Mount Pleasant can be seen in Section 6.0.

### 1.2.2 Future Flow Projections

Table 1-1 below outlines the influent flow projections for Rifle Range Road WWTP through the buildout year of 2049. The projected influent flow for the 20-year planning period (2034) is 8.4 mgd. MPW has developed strategies as to when plant expansions should occur to accommodate for the flow projections shown in the table below. In addition, the 20-year Flow Projections chart can be seen in Section 6.0. This chart illustrates the projected flow increase for RRR and when capacity increases will occur. The chart will be adjusted year-to-year as actual plant flow data is collected.

**Table 1-1 Influent Flow Projections**

CRITERIA	PF	2014	2019	2034	2049
Annual Average (AA)	1	5.8	6.6	8.4	10
Maximum Month (MM)	1.15	6.7	7.6	9.7	11.5
Peak Day (PD)	1.55	9	10.2	13.0	15.5
Peak Hour (PH)	2.5	14.5	16.5	21.0	25.0

## 1.3 PROJECT SCHEDULE

- Start of Construction: March 2018
- Completion of Construction: December 2020

<sup>1</sup> CDM Smith, Draft Water Demand and Wastewater Flow Factors and Future REU Projections, (South Carolina, Mount Pleasant Waterworks, 2014), 1-16.

## 2.0 Project Requirements

### 2.1 RECEIVING WATERS

The 24-inch effluent force main from the RRRWWTP, which discharges through Outfall 002, carries treated wastewater to Ben Sawyer Boulevard, where it is upsized to a 30-inch force main and continues to the Center Street Wastewater Treatment Plant (CSWWTP) and to the final effluent discharge point at the Charleston Harbor, Outfall 005. Two reverse osmosis water treatment plants, owned by MPW, also discharge through Outfall 005 along with the RRRWWTP and CSWWTP. Reference the United States Geological Survey Map (NPDES Outfall) in Section 6.4 for the discharge location for Outfall 005.

### 2.2 CONSTRUCTION CONTRACT

The improvements outlined in this Preliminary Engineering Report will be included in a single set of Contract Documents. In order to maintain permit compliance during construction, detailed construction sequencing requirements will be included in the Contract Documents.

### 2.3 PROJECT DATUM

The vertical datum to be used for this project is the North American Vertical Datum of 1988 (NAVD88). The horizontal datum to be used is the North American Datum of 1983 (NAD83).

### 2.4 LOCAL FLOOD LEVELS

In accordance with South Carolina Department of Health and Environmental Control (SCDHEC) Regulation 61-67 (May 2015), wastewater treatment plants are required to be fully operational during flooding from a 25-year flood and to be protected from physical damage from flooding from a 100-year flood. The current FEMA flood map is dated 2004; however, FEMA has issued a new preliminary Flood Insurance Rate Map (pFIRM) which will go into effect in 2018. This design will incorporate the flood zones as illustrated on this pFIRM. The majority of the plant and proposed plant expansion areas are within Zone AE with a flood elevation of 13.02 ft-NAVD88 (14.0 ft – NGVD29).

Based on Town of Mount Pleasant Code of Ordinance, Section 152.22 (B), new construction shall have the lowest floor elevated no lower than the design flood elevation. The design flood elevation is defined as the base flood elevation plus 1 foot. The base flood elevation is equal to the 100-year flood elevation. The 100-year flood elevation (base flood elevation) provided by FEMA for the zone where the improvements are proposed is 13.02 ft-NAVD88 (14.0 ft-NGVD29) and the design flood elevation is 14.02 ft-NAVD88 (15.0 ft-NGVD29). The 50-year flood elevation is 11.2 ft-NAVD88.

The existing septage receiving facility, plant drain pump stations, and scum pump stations are submerged at a 14-foot elevation. Submergence of these facilities does not affect the operation of the plant but action is required to protect them from damage.



## 2.5 SOURCES OF UTILITIES

- Water: Mount Pleasant Waterworks (843) 884-9626
- Electric: South Carolina Electric and Gas (866) 913-9762

## 2.6 PERMITTING

The RRRWWTP operates under NPDES permit number SC0040771, dated October 1, 2013. As in permit SC0040771, the RRRWWTP will continue to dispose of its sludge by land filling. The plant's NPDES permit will need to be revised to reflect the new discharge capacity of the facility. This preliminary engineering report (PER) will be submitted to DHEC for the project to support the permit applications for the NPDES permit (including Form 2A).

Wastewater projects are reviewed by the Berkeley-Charleston-Dorchester Council of Governments (BCDCOG) to determine whether or not they conflict with the applicable 208 Water Quality Plan. The BCDCOG makes recommendations to the South Carolina Department of Health and Environmental Control (SCDHEC) on whether or not to permit a particular project based on these reviews. This PER will be submitted to BCDCOG for the project to support the permit application for the NPDES permit.

A wastewater facility construction permit from DHEC will be required to construct the improvements to the RRRWWTP. This permit will require review and approval of the final construction documents. SCDHEC coordinates with the Office of Coastal Resource Management (OCRM) for a consistency review prior to approving construction permits.

A local construction permit will also be required from the Town of Mount Pleasant. This permit will include review for building code compliance, storm water control for construction and completed drainage, fire code compliance, flood control, and tree ordinance compliance. Review by the Town of Mount Pleasant will also require an OCRM consistency review.

## 2.7 RELIABILITY CLASSIFICATION

SCDHEC establishes reliability classification requirements for wastewater treatment plants for the purpose of protecting surface waters. There are three levels of reliability classification, with Reliability Classification I being the most restrictive. The Rifle Range Road WWTP is located in the Sewee-Santee watershed and discharges to the Charleston Harbor. Based on SCDHEC's methods for determining reliability classifications, the Rifle Range Road WWTP is governed by requirements for Reliability Classification III.

The upgrade and expansion of the Rifle Range Road WWTP will be designed to meet Class III Reliability requirements as determined by SCDHEC. The Class III Reliability requirements mandate that backup components and auxiliary power be incorporated into the design of the plant expansion.

**Table 2-1 Reliability Classification III**

REGULATION	CLASS III RELIABILITY REQUIREMENTS FOR WWTFs <sup>1</sup>	DESIGN DOCUMENT REFERENCE	COMMENTS
67.400.B.8	Influent and effluent PS are considered part of the WWTP for purposes of applying reliability class criteria.	Reference section 3 for the effluent pumps. Reference section 5 for the influent pumps.	The plant has an existing effluent pump station. A new influent pump station will be constructed.
67/400.C.2	For the sludge management system, a backup pump shall be provided for each set of pumps which performs the same function. The capacity of the pumps shall be such that with any one (1) pump out of service, the remaining pumps shall have capacity to handle peak flow. It is permissible for one (1) pump to serve as a backup to more than one (1) set of pumps in a typical pump station.	M-100-101 and M-105-101	Providing a backup pump for each set of pump which performs the same function with capacity such that with any 1 pump out of service, the remaining pumps can handle peak flow.
67.400.C.3	When anaerobic digestion is utilized, at least two (2) anaerobic digestion tanks shall be provided	Not Applicable.	Not Applicable.
67.400.C.4	For aerobic digestion, at least two (2) blowers and/or mechanical aerators shall be provided. If only one (1) blower and/or aerator is installed, the backup shall be of equal size and the installed blower and/or aerator shall be easily removed and replaced.	G-000-006	Three blowers will be installed as part of the aeration system.
67.400.C.6	There shall be a sufficient number of centrifuges and belt presses provided to enable the design sludge flow to be dewatered with the largest unit out of service. An alternative sludge management plan (e.g., use of existing sand drying beds as a backup) may be proposed for the purpose of justifying the need for only one (1) unit.	See section 5 of the preliminary engineering report for design criteria for the belt filter press.	Two belt filter presses will be provided to meet the max month sludge flow condition.
67.400.D.4	When mechanically cleaned bar screens are utilized, provisions for backup bar screen, which may be designed for manual cleaning, shall be provided.	G-000-006	Two mechanical bar screens and a backup bar screen will be provided at the new headworks facility.

REGULATION	CLASS III RELIABILITY REQUIREMENTS FOR WWTFs <sup>1</sup>	DESIGN DOCUMENT REFERENCE	COMMENTS
67.400.D.6	When clarifiers are utilized, all domestic WWTFs shall have at least two (2) clarifiers provided when the design flow of the WWTF exceeds one hundred thousand (100,000) gallons per day.	G-000-006 and section 5	The existing plant has three clarifiers. The solids and hydraulic loading rates are identified in section 5.
67.400.D.7	Intermediate sedimentation basins and tertiary filters shall be designed with sufficient number of units such that with the largest flow capacity unit out of service, the remaining units shall have a design capacity such that the appropriate design criteria are not exceeded, based on 75% of design flow.	Not Applicable.	See Reg. 67.400.E.3 and Reg 67.400.F.5
67.400.D.8	Aeration blowers and/or mechanical aerators shall be provided in sufficient number to enable the design oxygen transfer to be maintained with the largest capacity unit out of service. It is permissible for the backup unit to be an un-installed unit, provided that the installed unit can be easily removed and replaced.	See section 5 of the preliminary engineering report.	The capacity of the aeration basin blowers will be such that with the largest blower out of service, the remaining blowers will have the capacity to provide the maximum month average oxygen demand (with residual DO of 2 mg/L) and peak day oxygen demand (no DO residual requirement). See Reg. 67.400.F.3
67.400.D.9	Air diffusion systems shall be designed such that the largest section of diffusers can be isolated without measurably impairing the oxygen transfer capability of the system.	See section 5 of the preliminary engineering report.	The air diffusion system in the aeration basins will be designed such that the largest section of diffusers can be isolated without measurably impairing the oxygen transfer capability of the system. Each of the three aeration basins will be provided with three diffuser zones.

REGULATION	CLASS III RELIABILITY REQUIREMENTS FOR WWTFs <sup>1</sup>	DESIGN DOCUMENT REFERENCE	COMMENTS
67.400.D.10	Where proposed or required, all domestic wastewater treatment facilities and industrial wastewater treatment facilities as determined by the Department, shall have at least two (2) chemical flash mixer basins provided, or a backup means of adding and mixing chemicals, separate from the basin, shall be provided. If only one (1) basin is provided, at least two (2) mixing devices and a bypass around the basin shall be provided. It is permissible for one of the mixing devices to be un-installed, provided that the installed unit can be easily removed and replaced.	M-080-102	Existing chlorine contact basin has a single flash mixer structure with a single mixing device which can be removed and replaced.
67.400.E.3	Primary and final sedimentation basins and trickling filters shall be designed with sufficient number of units such that with the largest flow capacity unit out of service, the remaining units shall have a design flow capacity of at least 50% of the design base flow to that unit operation.	See section 5 of the preliminary engineering report.	The secondary clarifiers have sufficient capacity such that with the largest flow capacity unit out of service, the remaining units can treat in excess of 50 percent of annual average design flow without exceeding the design criteria. See Reg. 67.400.D.7 and Reg. 67.400.F.5
67.400.E.5	Disinfection components, including basins shall have sufficient number of units such that with the largest flow capacity unit out of service, the remaining units shall have a design flow capacity of 50% of the total design average flow to the unit operation.	See section 5 of the preliminary engineering report.	With the largest contact chamber out of service the remaining two chambers exceed the design flow capacity of 50% of the total design average flow.
67.400.E.6	Holding basins or equivalent design features may not be required.	G-000-006	This project includes two new equalization basins with a total volume of 3.5 million gallons. The total volume of the equalization basins will store the peak hour flow (23 mgd) in excess of the effluent force main capacity of 14 mgd.

REGULATION	CLASS III RELIABILITY REQUIREMENTS FOR WWTFs <sup>1</sup>	DESIGN DOCUMENT REFERENCE	COMMENTS
67.400.E.7	Backup pump requirements for WWTF shall be determined on an individual basis.	G-000-006	Providing a backup pump for each set of pump which performs the same function with capacity such that with any 1 pump out of service, the remaining pumps can handle peak flow.
67.400.F.3	When blowers or mechanical aerators are utilized, all domestic facilities and industrial facilities as determined by the Department, shall have at least 2 aeration blowers and/or mechanical aerators available for service. One of the units can be uninstalled, if the installed unit can be easily removed and replaced.	G-000-006	Providing three aeration blowers. See Reg. 67.400.D.8
67.400.F.4	For all domestic facilities and industrial facilities as determined by the Department, a single aeration basin is permissible.	G-000-006	Providing three aeration basins.
67.400.F.5	When sedimentation basins are utilized, all domestic facilities and industrial facilities as determined by the Department, shall have at least 2 primary, intermediate, and final sedimentation basins provided.	G-000-006	The existing plant has three secondary clarifiers. See Reg 67.400.D.7 and Reg 67.400.E.3
67.400.F.6	For all domestic wastewater treatment facilities and industrial wastewater treatment facilities as determined by the Department, the backup power source shall be sufficient to operate the screening facilities, the main wastewater pumps, the primary sedimentation basins, and the disinfection facility during peak wastewater flow condition, together with critical lighting and ventilation.	See section 5 of the preliminary engineering report.	A backup power source will be provided sufficient to operate all vital components required to meet effluent disposal permit limitations during peak wastewater flow conditions, together with critical lighting and ventilation.

Notes:

Items listed are taken from South Carolina DHEC Standards for Wastewater Facility Construction Regulation R.61-67, updated June 26, 2015.

## 2.8 ALTERNATIVES EVALUATION

### 2.8.1 Reuse

Effluent from RRRWWTP has been considered for reuse in the Mount Pleasant area. Currently, a total of 0.08 mgd is permitted for reuse at the MPW Operations Center, Sloan Park, and the Center Street Ball Fields. Other potential reuse customers have been identified in the Patriots Point area, but not enough reuse customers have been found to accept the anticipated flows from RRRWWTP. MPW continues to search for additional reuse customers and is currently revising its Reuse Master Plan.

### 2.8.2 Groundwater Recharge

As water supplies become more stressed, the use of treated wastewater to recharge underground aquifers is gaining more attention. As the population grows, water demands increase, which often forces water purveyors to rely more heavily on groundwater to meet the water demand. At the same time, the land area available to recharge aquifers is diminished in these same areas due to development. In many cases, the result is groundwater mining, where water is withdrawn from an aquifer faster than the aquifer is being recharged. The result is a lowering of the groundwater table, which in coastal areas can lead to saltwater intrusion into the freshwater aquifer. Thus, there is increasing interest in using treated wastewater to recharge stressed underground aquifers.

Aquifers are naturally recharged by rainfall, streams and lakes, and adjacent aquifers. Aquifers can be artificially recharged by creating surface infiltration areas in which water is allowed to percolate down to the groundwater table. Problems with this method include water loss due to evaporation and the requirement of large land areas being dedicated to surface infiltration, especially in areas where the soils are relatively impermeable. A primary advantage of this aquifer recharge method is that the water is naturally cleansed as it percolates through the soil.

Another way to artificially recharge aquifers is by direct injection of water into the aquifer through recharge wells, termed aquifer storage and recovery (ASR). This method has the advantage of not losing water to evaporation and not requiring the dedication of large land areas to surface infiltration. The disadvantage is that the injected water must be of high quality in order to prevent degradation of the aquifer water quality. Currently regulations do not allow injection of treated wastewater into aquifers in South Carolina. Limited work is being done with injection of treated wastewater in Florida and it may become feasible at some future time in South Carolina.

### 2.8.3 Connection to Another Wastewater Treatment Plant

The only other WWTP in the Mount Pleasant area is the Center Street Wastewater Treatment Plant (CSWWTP). This facility currently receives about 2.2 mgd AA flow and is permitted for a MM flow of 3.7 mgd. The facility is located on approximately four acres, and the area surrounding the facility is a densely developed residential area, making expansion of the existing facility difficult. Further, most development is occurring in the RRRWWTP service area rather than the CSWWTP service area. For these reasons, the option of diverting flow to the CSWWTP was discounted.

#### **2.8.4 Use of Land Application**

Different sludge disposal methods were evaluated in 2013 and it was determined that all sludge disposal will be done by landfill similar to current plant operations.

#### **2.8.5 Alternatives Selection**

Product or raw material substitution and other treatment options were evaluated and determined to not be economically and technologically feasible.

Based on the analysis of alternatives discussed above, there are no other alternatives available which are both economically and technologically reasonable, and which also minimize or eliminate environmental impacts. Therefore, it is necessary for both social and economic development in the MPW service area that an increase in the discharge flow is allowed under the anti-degradation provision of Section D of Regulation 61-68.

### 3.0 Existing Facilities

The existing process train consists of the following as shown in Table 3-1 and Figure 1-2 Existing Liquids and Solids Treatment Process Train.

**Table 3-1 Existing Facilities**

LIQUID PROCESS	SOLIDS PROCESS	AUXILIARY
Influent Screening	Sludge Holding Tanks	Standby Generators
Grit Removal	Sludge Dewatering	Plant Control System
Anoxic Selector Basins		Plant Water System
Oxidation Ditches		
Recirculation Pumping		
Secondary Clarifiers		
Sludge Pumps (RAS/WAS)		
Chlorine Contact Basins		
Effluent Pumping		

#### 3.1 INFLUENT SCREENING

The RRRWWTP has a 2-foot-wide mechanical perforated plate screen with 3-mm openings and a manual bar screen with 1-inch openings located upstream of the grit chamber. A third channel is available for installation of a future third screen. Raw wastewater enters the headworks through a 36-inch force main and passes through the mechanically cleaned perforated plate screen under normal conditions. During flow conditions in excess of 6 mgd, a portion of the flow is diverted through the manual bar screen. The existing 3-mm perforated plate screen was installed in 2016 to replace an existing automated screen that was at the end of its useful life. Screen information is shown in Table 3-2.

**Table 3-2 Influent Screens**

DESCRIPTION	DESIGN CRITERIA
Number of Screens	2
Type	One mechanically cleaned with 3-mm perforated plate screen and one manually cleaned with 1-inch bar spacing
Manufacturer	Parkson
Width	2 feet
Rated Capacity	15 mgd peak flow with mechanical screen only



### 3.2 VORTEX GRIT CHAMBERS

After screening, influent flows into a vortex-type grit removal chamber. Raw sewage flows through a long, narrow channel and then enters the grit removal chamber, where a helical flow pattern is developed. Tangential flow creates a vortex that moves grit to center of chamber where it settles to the bottom and is removed by a grit pump. The grit is pumped to a screw-type grit classifier where screenings are washed and conveyed to a dumpster. Information on the vortex grit chamber is shown below in Table 3-3.

**Table 3-3 Vortex Grit Chamber**

DESCRIPTION	DESIGN CRITERIA
Number	1
Manufacturer	Smith & Loveless PISTA Model 12.0
Rated Capacity	12 mgd peak flow

### 3.3 ANOXIC SELECTOR BASINS

Screened, de-gritted influent flows from the vortex grit chambers to two anoxic selector basins. Each basin has a volume of 0.17 MG and is divided into three zones, with the first two zones each constituting about 25 percent of the total volume, and the third zone comprising about 50 percent of the total volume. Each zone is mixed by submersible propeller mixers. Recirculation from the oxidation ditches, return activated sludge (RAS), and screened, de-gritted, raw sewage is mixed in the distribution chamber at the upstream end of the anoxic selector basins. Anoxic selector design information is shown below in Table 3-4.

**Table 3-4 Anoxic Selector Basin**

DESCRIPTION	DESIGN CRITERIA
Number	2
Basin Volume	0.17 MG each
Hydraulic Retention Time at 6.0 mgd annual average flow	1.36 hrs
Hydraulic Retention Time at 6.9 mgd maximum month flow	1.18 hrs
Estimated Capacity	7.1 mgd annual average flow

### 3.4 OXIDATION DITCHES

The existing activated sludge system consists of two Eimco, carrousel-type oxidation ditches. The volume of each ditch is 1.75 MG, or 3.5 MG total. Submersible-propeller pumps were installed in the far end to recirculate mixed liquor to the anoxic selector basins. Design criteria and basin information are summarized below in Table 3-5.

**Table 3-5 Oxidation Ditches**

DESCRIPTION	DESIGN CRITERIA
Number	2
Basin Volume	1.75 MG each
Winter Temperature	17 °C
Maximum Monthly Winter MLSS	3,000 mg/L
Maximum Monthly Winter SRT	7.9 days (including anoxic zone)
Maximum Monthly Winter WAS Production	11,200 lbs/d
Annual Average Design Temperature	23 °C
Annual Average MLSS	1,450 mg/L
Annual Average SRT	5.5 days (including anoxic zone)
Annual Average WAS Production	7,520 lbs/d
Estimated Capacity	5.7 mgd annual average flow

Oxidation ditch aeration is currently provided by two constant speed, 100-hp mechanical aerators per basin. Additional aeration is supplied by 252 membrane-type fine bubble diffusers per ditch located at the far end of the loop. Air is supplied to the diffusers in both basins by a single 100-hp, constant speed multistage centrifugal blower. Aeration is also supplied by two 50-hp floating aspirating aerators per basin. Aeration information is summarized below in Table 3-6.

**Table 3-6 Oxidation Ditch Aeration**

DESCRIPTION	DESIGN CRITERIA
<b>MECHANICAL AERATION</b>	
Number of mechanical aerators	2 per ditch
Motor horsepower	100 each
Transfer efficiency	2.6 lb O <sub>2</sub> /hr/hp
Number of aspirating aerators	2 per ditch
Motor Horsepower	50 each
Transfer efficiency	2.1 lb O <sub>2</sub> /hr/hp
<b>FINE BUBBLE DIFFUSED AERATION</b>	
Number of fine bubble diffusers	252 per ditch
Number of blowers	1 (serves both basins)
Blower Capacity	2,000 scfm at 8 psig, 100 hp

### 3.5 RECIRCULATION PUMPING

Mixed liquor is continuously recirculated from the oxidation ditches to the anoxic selectors by a single, submersible propeller-type pump in each oxidation ditch. The pumps are rated at 10.5 mgd at 4 feet of head. The total recirculation capacity is 21 mgd, or 318 percent of the maximum month flow of 6.6 mgd, which is adequate capacity. The recirculation pumping system has a spare pump on standby as a backup in the event of an equipment failure; however, this is not an issue because the anoxic selector represents a process enhancement and is not strictly required for meeting the plant effluent limits. Recirculation pumping is summarized below in Table 3-7.

**Table 3-7 Recirculation Pumping**

DESCRIPTION	DESIGN CRITERIA
Number of pumps	2, one per oxidation ditch
Type	Submersible, propeller
Manufacturer	Flygt, 4600 Series 20 hp
Capacity at 4-foot TDH	7,300 gpm (10.5 mgd), each 21 mgd, total
Recirculation ratio at 6.6 mgd maximum month flow	318%

### 3.6 SECONDARY CLARIFIERS

The RRRWWTP has three 75-foot-diameter secondary clarifiers. The clarifier sizing, equipment, and capacity information is summarized below in Table 3-8.

**Table 3-8 Secondary Clarifiers**

DESCRIPTION	DESIGN CRITERIA
Number	3
Diameter	75 ft
Surface area	4,418 ft <sup>2</sup> , each 13,254 ft <sup>2</sup> , total
Side Water Depth	16 ft
Sludge collection equipment	USFilter/Envirex Tow-bro rapid sludge withdrawal 0.5 hp constant speed drive
Surface Overflow Rate at 5.7 mgd annual average flow	430 gal/ ft <sup>2</sup> /day
Surface Overflow Rate at 6.6 mgd maximum month average flow	500 gal/ ft <sup>2</sup> /day
Surface Overflow Rate at 8.8 mgd peak day flow	670 gal/ ft <sup>2</sup> /day

DESCRIPTION	DESIGN CRITERIA
Surface Overflow Rate at 14.3 mgd peak hour flow	1,080 gal/ ft2/day
Design solids loading rate at maximum monthly flow (and RAS = 100% annual average)	25 lbs/ft2/day
Typical maximum monthly surface overflow rate	<700 gal/ ft2/day
Typical peak day surface overflow rate	<1,400 gal/ ft2/day
Typical maximum solids loading rate at maximum monthly load and 100% RAS return flow	<25 lbs/ft2/day
Estimated Capacity	5.7 mgd annual average flow

With three 75-foot secondary clarifiers, the RRRWWTP does not have any excess capacity. From a hydraulic standpoint, the clarifiers can take additional flow, but the limiting criterion for the system will be the solids loading rate. The aeration basins and secondary clarifiers are sized together, so in order to treat more flow, the oxidation ditches must be operated at a lower MLSS concentration. The solids loading rate of the secondary clarifiers is at the upper end of the recommended range at a flow of 6.6 mgd MM and a MM winter MLSS concentration of 3,000 mg/L .

### 3.7 RAS PUMPING

There are two RAS/WAS pumping stations to pump the RAS from the secondary clarifiers to the anoxic selectors. RAS Pumping Station 1 serves Secondary Clarifiers Nos. 1 and 2. RAS Pumping Station 2 serves Secondary Clarifier 3 and accommodates for a future Secondary Clarifier. The RAS pump capacity information is summarized in Table 3-9.

**Table 3-9 RAS Pumping**

DESCRIPTION	DESIGN CRITERIA
Number of pumps	3 in RAS Pumping Station 1 2 in RAS Pumping Station 2
RAS Pumping Station 1	2 pumps with 2.3 mgd @ 23 ft TDH, each 1 pump with 1.5 mgd @ 31.5 ft TDH
RAS Pumping Station 1, firm capacity	3.8 mgd (with one 2.3 mgd pump out of service)
RAS Pumping Station 2	2 pumps with 1.5 mgd @ 31.5 ft TDH, each
RAS Pumping Station 2, firm capacity	1.5 mgd (with one 1.5 mgd pump out of service)
Total Firm capacity	5.3 mgd
Total firm capacity required for 6 mgd plant	100% of annual average flow of 5.2 mgd
Firm Capacity as a Percentage of Maximum Monthly plant capacity	88% (of 6 mgd)

To provide the capability to operate under a number of loading and settleability conditions, the capability to pump a RAS flow equal to 100 percent of the annual average flow is usually considered a minimum requirement. Therefore, with a firm capacity of 5.3 mgd, the RAS pumps are right at their limit for the 6 mgd facility. Historically, the RRRWWTP MLSS has produced a very good settling sludge with a reasonable to low SVI and the existing RAS pumping is sufficient

### 3.8 WAS PUMPING

Each RAS/WAS pumping station listed in the section above has two WAS pumps, one duty and one standby. Based on the rated pump capacities shown in the table below, WAS pumping capacity is adequate.

**Table 3-10 WAS Pumping**

DESCRIPTION	DESIGN CRITERIA
Number pumps	2 per pumping station, 4 total
Rated capacity	288,000 gal/day, each pump, @ 33.5 ft TDH
Annual average WAS load at 5.7 mgd flow	7,520 lbs/d
Maximum monthly WAS load at 6.6 mgd	11,200 lbs/d
WAS solids concentration assumed	0.75%
WAS flow at 5.7 mgd Annual Average flow	120,200 gal/d
WAS flow at 6.6 mgd Maximum Monthly flow	179,100 gal/d

### 3.9 DISINFECTION

Secondary clarifier effluent is disinfected using sodium hypochlorite. The facility has two chlorine contact chambers with a total volume of 125,000 gallons. This provides a chlorine contact time of 30 minutes at 6 mgd flow and 12 minutes at 15 mgd (the peak hour flow for 6 mgd annual average) as summarized below in Table 3-11. Staff has been able to control the effluent chlorine residual such that no dechlorinating chemical addition is needed.

**Table 3-11 Disinfection**

DESCRIPTION	DESIGN CRITERIA
Number of Basins	2
Volume	62,500 gallons, each 125,000 gallons, total
Contact time at 6 mgd annual average flow	30 min
Contact time at 15 mgd peak hour flow	12 min
Sodium Hypochlorite Storage (30 days of storage)	1 bulk storage tank, 5,500 gallons 3 dilution tanks, 2,000 gallons each

DESCRIPTION	DESIGN CRITERIA
Sodium Hypochlorite dosage rate at 6 mgd average flow	5 mg/L
Sodium Hypochlorite dosage rate at 15 mgd peak hour flow	8 mg/L

### 3.10 EFFLUENT PUMPING

Treated effluent is discharged to the effluent pumping station. It is then pumped through a 30-inch force main approximately 26,000 feet to Outfall 005 in Charleston Harbor. Effluent from the CSWWTP and two reverse osmosis water treatment plants is also discharged into the force main. The discharge from the two water treatment plants averages 1 mgd and the CSWWTP currently discharges 3.2 mgd, although it is permitted to discharge 3.7 mgd and designed to discharge 9.3 mgd at peak hour. RRRWWTP currently receives an annual average flow of 5.2 mgd and a wet weather peak hour flow of 13.0 mgd. Data on the effluent pumps is shown below in Table 3-12.

**Table 3-12 Effluent Pumping**

DESCRIPTION	DESIGN CRITERIA
Number of pumps	5
Large pumps	Submersible 2 x 168 hp Variable speed Rated capacity 5,556 gpm at 92 ft TDH
Small pumps	Submersible 3 x 295 hp Variable speed Rated capacity 4,514 gpm at 180 ft TDH

### 3.11 SLUDGE STORAGE

Two sludge storage tanks exist for secondary scum and WAS. Liquid can be decanted from the surface to the plant drain. The tanks are aerated using coarse bubble diffusers. With the estimated sludge production rate for the 6-mgd plant, the sludge storage tanks provide about two days of sludge storage. Additional storage time is obtained through decanting within the WAS holding basins. Information regarding the sludge storage tanks is summarized in Table 3-13.

Rifle Range Road also receives sludge from Isle of Palms and Sullivan’s Island. Isle of Palms contributes 51,000 gallons per month and Sullivan’s Island seasonally contributes 25,000 gallons per month. These flows are irregular and are received at Plant Drain Pump Station #2 and pumped to Sludge Storage Tanks #1 and #2.

**Table 3-13 Sludge Storage**

DESCRIPTION	DESIGN CRITERIA
Number of tanks	2
Volume	187,000 gal, each; 374,000 gal, total
Sludge storage capacity at 5.7 mgd average flow and 0.75% solids	3.1 days
Sludge storage capacity at 6.6 mgd maximum monthly flow and 0.75% solids	2.1 days
Air/volume ratio	30 cfm/1000 ft <sup>3</sup>
Number of blowers	2 Rotary Positive Displacement
Blower capacity, scfm	750
Blower Discharge Pressure, psig	13
Blower Accessories	VFDs, Inlet and Discharge Silencers, Inlet Filters.
Number of BFP feed pumps	2 Vaughan model SE4L with VFD
BFP feed pump capacity	625 gpm at 47 ft TDH; 15 hp

### 3.12 DEWATERING

Dewatering is accomplished using one 2-meter wide belt filter press. WAS is transferred from the sludge storage tanks to the belt filter press. Filtrate is returned to the headworks, and cake is transported to a landfill for disposal. Performance data for the press is shown in Table 3-14.

It is estimated that at annual average flow of 5.7 mgd, the press will require operation 8.5 hours per day, 5 days per week. Over the past few years, the belt filter press experienced multiple mechanical issues resulting in downtime without dewatering operation. During these times, the plant treatment process was inhibited due to the inability to waste and dewater sludge. These downtimes expose the plant to permit violations and should be mitigated by implementation of additional sludge storage or a second belt filter press.

**Table 3-14 Belt Filter Press**

DESCRIPTION	DESIGN CRITERIA
Number of presses	1
Belt width	2 m
Raw sludge load at 5.7 mgd annual average flow	7,520 lbs/day
Raw sludge load at 6.6 mgd maximum month flow	11,200 lbs/day
Maximum BFP Hydraulic loading rate	300 gpm

DESCRIPTION	DESIGN CRITERIA
Maximum BFP Solids loading rate	1,250 lbs/hr
Number of hours of press operation at average load, 5 days per week	8.5 hrs
Number of hours of press operation at maximum month load, 5 days per week	12.6 hrs

### 3.13 SEPTAGE RECEIVING FACILITY

The septage receiving facility consists of a covered drain and manually cleaned bar screen. Septage flows through the bar screen to plant drain pump station 1. There is currently little holding volume and the septage enters the plant influent as a “spike” load. Also, this facility is below the FEMA floodplain elevation. Consideration should be given to add an isolation of the sump from the pump station to prevent stormwater from entering the plant.

### 3.14 HYDRAULIC PROFILE INFORMATION

Flow through the plant was evaluated under a number of hydraulic conditions, including average annual flow of 6.0 mgd, maximum month flow of 6.9 mgd, peak daily flow of 9.3 mgd, and peak hour flow 15 mgd.

During peak flows, the anoxic basin effluent weir is submerged. This does not present a problem as the anoxic selectors are a process enhancement. The vortex grit chamber is hydraulically overloaded in all flow scenarios.

The most important hydraulic issue at RRRWWTP involves effluent pumping and the effluent force main. Plant effluent is pumped through a force main (approximately 26,000 feet in length) to Charleston Harbor. The force main is shared by the CSWWTP and Reverse Osmosis Water Plants 1 and 3. While a detailed analysis of the force main hydraulics was not in the scope of this report, existing reports on the force main were reviewed. During peak flows in 2004, the force main was flowing at the design capacity based on pumping capacities. Flows from the RRRWWTP dominate the hydraulics in the force main, and as flows to the RRRWWTP have been increasing, the design capacity of the force main will be exceeded more frequently. Thus, the primary hydraulic limitation of the RRRWWTP will be effluent pumping to the outfall.



## 4.0 Project Design Criteria

### 4.1 WASTEWATER CHARACTERISTICS

Influent wasteload characteristics were determined on a mass basis using historical influent data as follows:

$$\text{Mass Load (lb/day)} = \text{Flow (mgd)} \times \text{Concentration (mg/L)} \times 8.34$$

Mass load is an important evaluation tool in the analysis of the historical influent plant data. During this analysis, mass loads were calculated for cBOD, TSS, TKN, and NH<sub>3</sub>-N. The annual (daily) average, maximum month, and peak day loads to the plant were then calculated so that the plant could be evaluated for its capability to meet the proposed permit limits under all conditions.

This type of mass load evaluation is consistent with Environmental Protection Agency (EPA) and Water Environment Federation (WEF) process modeling recommendations for wastewater treatment plants.

The design basis of the plant upgrade and expansion is summarized in Table 4-1.

**Table 4-1 Design Flows For 9.2 MGD Annual Average Flow**

CONDITION	FLOW, MGD
Annual Average	9.2
Maximum Month (AA x 1.15)	10.6
Peak Day (AA x 1.8)	16.6
Peak Hour (AA x 2.5)	23

Note that the peak day factor is low due to low infiltration and inflow (I&I). MPW is continuing work to further reduce I&I.

Table 4-2 summarizes the influent wastewater characteristics estimated for RRRWWTP 10.6 mgd MM plant expansion. The influent wastewater characteristics were developed utilizing historical data for January 2011 through June 2016 and assuming a continuation of historical flow and load peaking factors.

Table 4-2 RRRWWTP Wastewater Characteristics for 9.2 MGD Plant Capacity

PARAMETER	PEAK FACTOR	MGD	MG/L	LBS/DAY
<b>ANNUAL AVERAGE</b>				
Flow	N/A	9.2	N/A	N/A
CBOD <sub>5</sub>	N/A	N/A	193	14810
BOD <sub>5</sub> <sup>1</sup>	N/A	N/A	227	17420
TSS	N/A	N/A	178	13660
TKN	N/A	N/A	40.1	3080
TP	N/A	N/A	5.0	380
<b>MAXIMUM MONTH<sup>2</sup></b>				
Flow	1.15	10.6	N/A	N/A
CBOD <sub>5</sub>	1.6	N/A	269 <sup>4</sup>	23700
BOD <sub>5</sub> <sup>1</sup>	1.6	N/A	317	28000
TSS	1.3	N/A	201	17760
TKN	1.3	N/A	46.8	4100
TP	1.4	N/A	6.3	530
<b>PEAK DAY</b>				
Flow	1.8	16.6	N/A	N/A
CBOD <sub>5</sub>	2.1	N/A	N/A	31100
BOD <sub>5</sub> <sup>1</sup>	2.1	N/A	N/A	36580
TSS	2.0	N/A	N/A	27320
TKN	1.5	N/A	N/A	4620
TP	2.4	N/A	N/A	910
<b>PEAK HOUR</b>				
Flow <sup>3</sup>	2.50	23.0	N/A	N/A
Notes: 1. For influent wastewater, cBOD5 is typically 85% of BOD5. 2. Maximum month flow and loading condition was assumed to coincide. 3. Peak hour flow was difficult to evaluate as the effluent flow meter, up until May 2014, was limited to 10 mgd. 4. MM concentration = MM load/ MM flow/8.34. 5. PD Loads are AA load times peak day peaking factor.				

In addition to the plant influent wastewater flow, RRRWWTP receives loads from septage haulers. Through discussions with the plant staff, they identified that they receive between seven and ten septage loads per week, with an average truck load of 500 gallons. The septage loads are around 60 percent port-a-lets and 40 percent septic tanks. These loads constitute less than 1 percent of the current load to the facility, and therefore are not considered critical to the evaluation of the plant. With the intermittent nature of the discharge and the minimal loadings, it will be difficult to identify the impact of septage haulers on the facility.

## 4.2 PLANT PROCESS CAPACITY

The RRRWWTP is a 6.0 mgd plant being expanded to 9.2 mgd annual average (10.6 mgd max month) with plans for future expansion to 15 mgd. The design will include a conceptual plan for the 15 mgd expansion. The project will not include capital investment towards the facilities to reach the future 15 mgd expansion. The design capacity for each process unit is shown in Table 4-3.

**Table 4-3 Unit Process Design Capacity for 10.6 MGD Maximum Month Flow**

	9.2 MGD IMMEDIATE EXPANSION (9.2AA, 10.6MM, 16.6PD, 23.0PH)	15 MGD FUTURE EXPANSION (15AA, 17.3MM, 28.2PD, 37.5PH)
	MAX MONTH FLOW, MGD	FUTURE PLAN
Anoxic Basins (3)	10.6	Site layout for a total of 6 basins
Aeration Basins (3)	10.6	Site layout for a total of 6 basins
Aeration Basin Blowers (3)	10.6	Site layout for future blower building and blowers
Mixed Liquor Pumping (3)	10.6	Additional pumps needed
RAS Pumping (5)	10.6	Additional pumps needed
Secondary Clarifiers (3)	10.6	Site layout for six secondary clarifiers

## 4.3 HYDRAULIC CAPACITY

The hydraulic design will accommodate the peak flows, including recycle flows, outlined in Table 4-4 below.

**Table 4-4 Hydraulic Design Flows**

	9.2 MGD IMMEDIATE EXPANSION (9.2AA, 10.6MM, 16.6PD, 23.0PH)	15 MGD FUTURE EXPANSION (15AA, 17.3MM, 28.2PD, 37.5PH)
	FLOW, MGD	FLOW, MGD
Influent Force Main	25PH	Future Gravity Main
<b>INFLUENT PUMP STATION</b>		
Coarse Screen (1)	25PH	Future IPS

	9.2 MGD IMMEDIATE EXPANSION (9.2AA, 10.6MM, 16.6PD, 23.0PH)	15 MGD FUTURE EXPANSION (15AA, 17.3MM, 28.2PD, 37.5PH)
	FLOW, MGD	FLOW, MGD
Wet Well	25PH	Future IPS
Pumps (3+1 standby)	25PH, 8.33PH each	Future IPS
<b>HEADWORKS</b>		
Mechanical Screens (2)	25PH, 12.5PH each	Future Headworks
Manual Screens (1)	12.5PH for redundancy	Future Headworks
Grit Chambers (2)	24PH, 12PH each	Future Headworks
<b>DISTRIBUTION BOX</b>		
Distribution Box Anoxic/Aeration (1)	25PH	Future Distribution Box
<b>ANOXIC AND AERATION BASINS</b>		
Anoxic Basins (3)	25PH, 8.33PH each	Site layout for future basins
Aeration Basins (3)	25PH, 8.33PH each	Site layout for future basins; Add SC
<b>SECONDARY CLARIFIERS (SC)</b>		
RAS Pumping (5)	10.6MM, 3.5MM each	Additional pumps needed
Secondary Clarifiers (3)	23PH, 7.66PH each	Three additional secondary clarifiers required
SC Splitter Box (1)	25PH	Future Distribution Box
<b>CHLORINE CONTACT AND EFFLUENT PUMPING</b>		
Chlorine Contact (2)	25 PH, 12.5 PH each	Site layout for future
Effluent Pumping	14PD	Site layout for future
Effluent Force main	14PD	Site layout for future
<b>PIPING</b>		
IPS to Distribution Box	25PH	Future pipe
Distribution Box to Anoxic	25PH, 8.33PH each	Future pipe
Aeration to SC Splitter Box	25PH	Future pipe
SC Splitter Box to SCs	23PH, 7.66 each	Future pipe

Table 4-5 below identifies the flow conditions used to evaluate the plant hydraulic profile.

**Table 4-5 Hydraulic Profile Flow Conditions**

FLOWS CONDITION	INFLUENT (MGD)	RAS (MGD)	MLR (MGD)	RECYCLES <sup>1</sup> (MGD)
Buildout	25.0	11.5	23.0	1.0
Peak Day	16.6	10.6	21.2	1.0
Design	10.6	10.6	21.2	1.0
Average	9.2	9.2	18.4	1.0
Minimum	3.2	3.2	6.4	1.0
Notes:				
1. Recycle is the plant drain pump station one two or three and septage receiving flows.				

The following table identifies the solids loading conditions used to evaluate the plant solids production rate.

**Table 4-6 Existing and Buildout WAS Production Rates**

FLOW (MM)	WAS PRODUCTION (MM)	
	lb/day	lb/week
6.6	11,200	78,400
10.6	18,200	127,400
17.3	29,500	206,500

#### 4.4 PERMIT LIMITS

The RRRWWTP is currently permitted for 6 mgd monthly average discharge through Outfall 002 and a total of 0.047 mgd as spray irrigation (Outfall 006 and 008). However, while the RRRWWTP discharges through Outfall 002, the final point of discharge to Charleston Harbor is through Outfall 005 as shown in on the United States Geological Survey (USGS) map included in section 6.0 of this document. Two reverse osmosis water treatment plants and the CSWWTP, all owned by MPW, also discharge through Outfall 005. RRRWWTP permit compliance is determined by samples taken from Outfall 002 and is not dependent upon the common Outfall 005.

The Effective RRRWWTP Limits consider the limits on both Outfall 002 and Outfall 005 and include the more restrictive of the two. These permit limits issued by SCDHEC identify that the current plant is rated for 6 mgd at AA flows. As the permit requirements for Outfall 002 are concentration dependent, these values are likely to remain similar for an expanded capacity of 9.2 mgd and beyond, unless there is degradation in the water quality parameters of the receiving water body. However, the UOD values for Outfall 005 are based on a TMDL for the Harbor and are therefore mass allocations for this outfall. It is unlikely that SCDHEC will increase the mass allocation for this

outfall, and therefore the effective concentration of UOD allowable for the expansion will decrease in proportion to the increase in flow.

The effluent limits used as the basis for design are those listed in the draft NPDES wasteload allocation letter provided by SCDHEC on December 13, 2016 and are as indicated in the following Table 4-7.

**Table 4-7 Rifle Range Road WWTP Current and Draft NPDES Permit Requirements**

PARAMETER, UNITS	CURRENT PERMIT FOR RRRWWTP THROUGH OUTFALL 002 @ 6 MGD		DRAFT PERMIT LIMITS FOR RRRWWTP THROUGH OUTFALL 002 @ 9.2MGD	
	MONTHLY AVERAGE	WEEKLY AVERAGE	MONTHLY AVERAGE	WEEKLY AVERAGE
Flow, mgd	MR	MR	MR	MR
Total Suspended Solids, mg/L	30 (85% removal)	45	30	TBD <sup>8</sup>
CBOD <sub>5</sub> , mg/L	25 (85% removal)	37.5	25 <sup>9</sup>	TBD <sup>8</sup>
Ammonia Nitrogen, mg/L (March – October)	20	30	20 <sup>9</sup>	TBD <sup>8</sup>
Ammonia Nitrogen, mg/L (November – February)	MR	MR	TBD <sup>8</sup>	TBD <sup>8</sup>
Ultimate Oxygen Demand (UOD), lbs/d (March – October)	N/A	N/A	N/A	N/A
Ultimate Oxygen Demand (UOD), lbs/d (November – February)	N/A	N/A	N/A	N/A
Enterococci, MPN/100 mL	35/501	N/A	35/501	N/A
Mysidopsis bahia Chronic Whole Effluent Toxicity @ CTC=1%	25% <sup>5</sup>	N/A	100% <sup>10</sup>	N/A
Total Residual Chlorine, mg/L	1.0 <sup>6</sup>	MR	1.0 <sup>6,7</sup>	MR <sup>8</sup>
Dissolved Oxygen, mg/L	1.0 (minimum)	1.0 (minimum)	1.0 (minimum)	1.0 (minimum)
pH, standard units	6-9.0	6-9.0	6-9.0 <sup>8</sup>	6-9.0 <sup>8</sup>

Notes:

<sup>1</sup>MR = Monitoring Requirement

<sup>2</sup>N/A = Not applicable

<sup>3</sup>UOD = 1.5 x cBOD<sub>5</sub> + 4.57 x NH<sub>3</sub>-N

<sup>4</sup>Daily maximum of 501. The permit may be modified to reduce the measurement frequency after one year of testing; expected completion October 2014.

<sup>5</sup>Daily maximum of 40%. The permit may be modified to remove this testing requirement after four tests; expected completion October 2015.

<sup>6</sup>Daily maximum of 1.5mg/l.

<sup>7</sup>Monthly average of 1.0 mg/l.

<sup>8</sup>To be determined and did not define in draft permit limits dated December 13, 2016.

<sup>9</sup>Maximum allowable so long as UOD limits are not exceeded.

<sup>10</sup>Toxicity test concentrations can be changed subject to Mixing Zone Evaluation. Have questioned the state and are awaiting clarification.

## 5.0 Facility Design Criteria

### 5.1 WASTEWATER TREATMENT PLANT IMPROVEMENTS

Improvements to the RRRWWTP will expand the treatment capacity from 6.9 mgd to 10.6 mgd MM flow and meet the new NPDES permit limits. Facility improvements include the following:

- New influent force main piping sized for peak hour flows of 25 mgd.
- New influent pump station with ½-in. multi-rake mechanical screen sized for peak hour flows of 25 mgd and four submersible pumps (three duty and one standby) sized for peak hour flows of 25 mgd.
- Construction of a new headworks facility with:
  - Two new 12.5 mgd mechanical screens
  - One manual bar rack with 5/8-in. bar spacing
  - Two vortex grit removal systems sized for peak hour flows
- Relocate of the existing biofilter odor control system to the new headworks location.
- Convert both existing carrousel into flow equalization basins.
- Build four new anoxic/aeration basins with a 20-ft SWD and 2.25 MG volume each.
- New anoxic selector basins.
- New blower building and gearless turbo blowers with the capacity to meet the maximum month airflow requirement with one blower out of service.
- Expand the existing chlorine contact basin to provide the required contact time at peak hour flow 25 mgd.
- Convert both existing anoxic selector basins into one sludge storage tank
- A new dewatering building to house two-two meter belt filter presses.
- Site work and major piping required for new equipment.
- Electrical/Instrumentation and Control – includes expanding the fiber-optic network to include new PLCs that are installed as part of the improvements above to result in a true redundant path fiber-optic network; improvements to the HMI system including redundant I/O servers, high-availability Historian and additional workstations throughout plant; incorporating any new instruments associated with the above improvements.
- Major Power Distribution components –new main switchgear and new load centers.
- Standby power components include - two existing 900 kw engine generators.



## 5.2 INFLUENT LINE

As shown on the Site Plan (C-001-101), the proposed location for the new headworks and influent pump station facility is approximately 200 feet north of the existing oxidation ditch and approximately 850 feet east of Rifle Range Road. At this location, approximately 875 linear feet of new 36-inch diameter force main piping will be needed to route wastewater from the collection system pipeline at Rifle Range Road to the new headworks and influent pump station. Installation of the gravity line described in Alternative 4 of the *Influent Pump Station and Headworks Alternatives Evaluation Technical Memorandum* (Oct 2016) and *Rifle Range Road WWTP Collection System Gravity Line Option from RPS 2 to the WWTP Technical Memorandum* (HDR, Oct 2016) will be deferred to a future project. The force main pipeline invert will enter the influent pump station at approximately elevation 3.00 ft-NAVD88. It will be necessary to coordinate the installation of the 36-inch diameter force main and connections to the existing 20-inch force mains along Rifle Range Road with the existing South Carolina Electric & Gas distribution power line right-of-way. Additionally, the force main route will cross the Sea Side canal which will potentially require a permit with the U.S. Army Corps of Engineers.

## 5.3 INFLUENT PUMPING STATION

The new influent force main will connect to the new influent pump station located upstream of the headworks facility. Therefore, the pump station must have a capacity which can handle all typical diurnal influent flows, including inflow and infiltration from storm events. Firm pump capacity provided will be 25 mgd with three duty pumps and one standby pump. The wetwell structure is sized for the peak hour flow of 25 mgd. For future plant expansion to a peak hour flow of 37.5 mgd, the wetwell can be expanded to the west of the current proposed location. The pumps will be supplied with variable frequency drives (VFDs) which will allow the pumps to provide a reduced capacity of approximately 3.0 mgd. The station will include one 25 mgd mechanically cleaned multiple rake bar screen and one bypass channel upstream of the pumps.

**Table 5-1 Mechanically Cleaned Multi-Rake Screen**

DESCRIPTION	DESIGN CRITERIA
Tag Designation	Bar Screen
Type	Mechanically Cleaned Multi-Rake Bar Screen
Manufacturer, Model	Vulcan VMR, Headworks Bar Screen MS2, Hydro-Dyne Tiger Shark, Huber RakeMax, Kusters Water ProTector
Control	Continuous duty, electric motor
Rated Capacity, mgd	25 peak flow
CHANNEL DIMENSIONS	
Channel Width, in.	36
Channel Depth, ft.	24

DESCRIPTION	DESIGN CRITERIA
<b>SCREENING UNIT DIMENSIONS</b>	
Screen Openings, mm	12
Screen Field Width, in.	34
Screen Field Height, in.	96
Screen Angle, °	80 (vertical)
<b>HYDRAULIC DESIGN CONDITIONS</b>	
Max Flow Capacity, mgd	25
High Liquid Level (at max. flow, downstream), ft.	6.0
Low Liquid Level (at min. flow, downstream), ft.	2.45
Total Headloss @30% Blocked, in.	14.0

It is anticipated that the future influent gravity main will enter the influent pump station at elevation -6.42 ft-NAVD88. As such, the wetwell will be constructed to accommodate this future elevation with the wetwell bottom at elevation -19.50 ft-NAVD88 and the normal hydraulic operating range of the influent pump station wetwell will be between elevation of -7.42 ft-NAVD88 and -12.08 ft-NAVD88. The wetwell elevation will allow for the equalization basin, septage receiving facility, odor control facility, aeration basin, and grit chambers to drain by gravity to the wetwell and will provide a reduction of the hydraulic head in the collection system.

**Table 5-2 Influent Pumping Station**

DESCRIPTION	DESIGN CRITERIA
Quantity	3 duty + 1 standby
Tag Description	Influent Pump 1, Influent Pump 2, Influent Pump 3, Influent Pump 4
Type	Submersible
Manufacturer	ABS, Flygt, KSB
Control	Local, plant control system and backup level control
Max. Capacity, mgd	33.33
Firm Capacity, mgd	25 (8.33 each)
<b>HYDRAULIC DESIGN CONDITIONS</b>	
Wet Well Volume, cubic ft	4,642
Maximum Month, mgd	11.5

DESCRIPTION	DESIGN CRITERIA
Peak Day Flow, mgd	18
Peak Hour Flow, mgd	25

Control of the influent pumps will be provided through three different methods: local, plant control system and backup level control. Primary control of the pumps will be based on the water level in the wetwell. When the water surface elevation reaches LEAD ON, Influent Pump 1 will start running at 50% speed and will increase speed as the water surface elevation increases to LAG1 ON. If Influent Pump 1 is running at 95% speed or more or fails to start for one minute, Influent Pump 2 will start running at 50% speed and will increase speed as the water surface elevation increases to LAG2 ON. If Influent Pump 1 and Influent Pump 2 are running at 95% speed or more or if either one fails to start for one minute, Influent Pump 3 will start running at 50% speed and will increase speed as the water surface elevation increases. As the water surface elevation decreases, the pump speeds will be reduced correspondingly. If three pumps are running at minimum speed for one minute, Influent Pump 3 will stop running. If two pumps are running at minimum speed for one minute, Influent Pump 2 will stop running. If one pump is running at minimum speed for one minute and the water surface elevation is less than PUMP OFF, Influent Pump 1 will stop running. Emergency backup control mode will be initiated when the water surface elevation reaches the high-high alarm float level and the PLC is not functioning. Clean out mode will run all pumps until the water surface level in the wetwell reaches PUMP OFF elevation and all pumps will stop. This will be an automatic mode set up to run during low flow period to help prevent a solid grease layer forming and solidifying based on a constant wetwell water surface elevation.

#### 5.4 INFLUENT PUMP STATION MOTOR CONTROL CENTER

All electrical and control equipment associated with the Influent Pump Station and Headworks will be housed in a standalone Influent Pump Station (IPS) Control Building. This building will house a motor control center for IPS and headworks loads, the VFDs for the influent pumps, control panels for the bar screens and screenings compactors, PLC for the area, additional miscellaneous panels required for the IPS and headworks areas and an HVAC system. This building will be fed with electrical power from the main switchboard in the main power distribution center.

The IPS Control Building will have a floor elevation at approximately 14 ft which is one foot above the Base Flood Elevation of the area. To house the electrical and control equipment and allow for the appropriate clearances, the building will be approximately 43 ft in length by 13.5 ft wide. The interior height of the building will be determined based on the required clearances of the installed equipment and is expected to be at a minimum height of 12 ft from the finished floor.

#### 5.5 HEADWORKS

The new headworks facility will be constructed with an operating floor at elevation 36.0 ft-NAVD88 to meet the hydraulic requirements of the current plant expansion. This elevation was selected to meet the HGL of the proposed improvements and expansion options to be implemented in downstream structures. The new headworks will include two mechanically cleaned center flow band screens, each with a rated hydraulic capacity of 12.5 mgd and a manual bar rack followed by

two 12 mgd vortex grit removal chambers. This equipment is discussed in more detail in the sections below.

### 5.5.1 Mechanical Screening

It is recommended that the existing screening equipment be replaced with new screening equipment ideal for the future plant capacities. The new screening equipment will be placed in a new headworks facility located on the acquired property north of the existing Aeration Basins and adjacent to the new influent pump station. The new screen channels will have a floor elevation of 28.5 ft and a hydraulic elevation of 32.9 ft upstream of the new screening equipment.

Influent flow enters each of the two channels and is directed into the screening unit where it is diverted through the two screening surfaces, perpendicular to the influent flow of the channel. Effluent from each screen exits the band screen unit and converges in the channel. Figure 5-1 below illustrates the general flow path for the new center flow band screens.

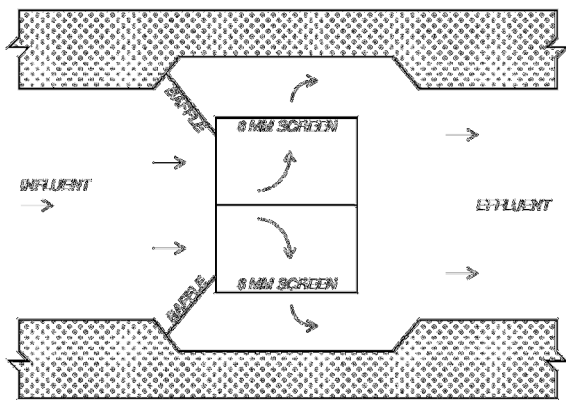

**Figure 5-1 Center Flow Band Screen Flow Path**

Each screening unit will have 5 mm perforations and be capable of handling a peak flow of 12.5 mgd. The required channel width is 24 in. with an additional 24 in. (48 in. total) at each unit for proper hydraulic flow exiting the screen (see Figure 5-1 above). The screens are automatically cleaned using a system of spray nozzles to direct pressurized water across the width of the screen and send screenings to the compactors. Table 5-3 below summarizes key characteristics of the center flow band screens.

**Table 5-3 Mechanical Screens**

DESCRIPTION	DESIGN CRITERIA
Tag Designation	Band Screen 1, Band Screen 2
Type	Center-Flow Band Screens
Manufacturer, Model	Hydro-Dyne Great White, Ovivo Bracket Green, JWC Muffin Monster
Control	Continuous duty, electric motor
Rated Capacity, mgd	12.5 peak flow per band screen

DESCRIPTION	DESIGN CRITERIA
<b>CHANNEL DIMENSIONS</b>	
Channel Width, in.	24 (48 at a screening unit)
Channel Depth, in.	78.0
<b>SCREENING UNIT DIMENSIONS</b>	
Screen Openings, mm	5
Length of Screen, in.	139.36
Depth of Screen, in.	43.47 (2 screening surfaces per unit)
Band Inlet Width, in.	32.0
Screen Angle, °	0 (vertical)

### 5.5.2 Manual Screening

In addition to the two mechanically cleaned screens, a single manual bar rack will be installed within a third channel in the headworks. During normal conditions, flow will pass through the two mechanical screens. An overflow weir will be constructed in the screening channels that will allow a portion of the raw wastewater to be diverted to the manual bar rack during high flow conditions or in the event of a mechanical screen failure. Table 5-4 below highlights key design parameters for the manual bar rack.

**Table 5-4 Manual Bar Rack**

DESCRIPTION	DESIGN CRITERIA
Tag Designation	Influent Bar Rack 1
Type	Manually Cleaned Bar Rack
Control	Manually
Channel Width, in.	24
Channel Depth, in.	78
Bar Width, in.	3/8
Bar Spacing, in.	1

### 5.5.3 Grit Removal

A new grit removal system is recommended to handle the current and future grit removal needs. The new grit removal system will be located in the new headworks and will have two vortex grit units installed, each with a capacity of 12 mgd. The units will include 3-ft wide approach channels and discharge channels and flooded-suction grit pumps. Each grit pump will send the grit to one of

two grit concentrators which will be connected to one grit conveyor. Controls for the equipment will be supplied by the vendor.

**Table 5-5 Grit Removal System**

DESCRIPTION	DESIGN CRITERIA
Quantity	2
Tag Designation	Grit Unit 1, Grit Unit 2
Type	Vortex Grit Removal
Manufacturer	Smith & Loveless
Control	Continuous duty electric motor drive head assembly, 1.5 hp
Rated Capacity, mgd	12, peak flow per chamber
Upper Chamber Diameter, ft	12
Max Water Depth, ft	4'-6"
Upper Chamber Depth, ft	6'-8"
Lower Chamber Diameter, ft	5'-0"
Lower Chamber Depth, ft	6'-8"
Grit Removal Performance	95%
<b>GRIT PUMPS</b>	
Quantity	2 ( 1 per basin)
Tag Designation	Grit Pump 1, Grit Pump 2
Type	Flooded suction, centrifugal
Manufacturer	Smith & Loveless
Max Capacity, gpm	250 gpm
Motor Rating, hp	5
<b>GRIT CONCENTRATOR</b>	
Quantity	2 ( 1 per basin)
Tag Designation	Grit Concentrator 1, Grit Concentrator 2
Manufacturer	Smith & Loveless
Control	Constant rate vortex
Max Capacity, gpm	250
Min. Influent Water Removal, %	93
Min. Influent Organics Removal, %	93

DESCRIPTION	DESIGN CRITERIA
<b>DEWATERING SCREW GRIT CONVEYOR</b>	
Quantity	1
Tag Designation	Grit Conveyor
Manufacturer	Smith & Loveless
Max Inflow Capacity, gpm	500
Full Pitch Screw Angle, °	22
Diameter of Screw, in.	14
Min. Length of Screw, ft	17
Motor Size, hp	1

### 5.6 SEPTAGE AND VACUUM TRUCK RECEIVING FACILITY

The septage receiving facility will be located on the east side of the headworks. It is designed to allow trucks to drive on to the 20-ft by 20-ft concrete pad and connect a hose to either a 6-in. diameter or a 4-in. diameter drain pipe with a camlock connector located above the flood elevation. Additionally, the pad will be sloped to a center drain area with bolted grating for spill containment and wash down. There will also be a 4-in. pipe with a hinged cover for RV connections. The piping and drain will be connected to a manhole. Two 1 ½-in. yard hydrants, one non-potable water and one plant service water, will also be provided.

A separate 56-ft by 52-ft pad containing two sediment dewatering containers will also be provided. An eight-inch diameter common drain line from the manhole at the septage receiving facility and the sediment dewatering container area will drain by gravity to the influent pump station. It is anticipated that the invert of the drain pipe at the influent pump station will be 0.00 ft-NAVD88.

### 5.7 EQUALIZATION BASINS

On-site equalization utilizes basin capacity to hold or store process flows that exceed the capacity of mechanical or biological unit processes. Once the peak flow has receded, the stored volume is conveyed back into the process for treatment or pumping. An additional advantage to on-site equalization is that the equalization volume can be used to establish a consistent flow throughout the day to buffer influent flows.

There are currently two existing aeration carousel basins, each with a volume of 1.75 MG. The existing carousels will be converted into Equalization (EQ) Basins (Wet Weather Tank #1 and Wet Weather Tank #2). The EQ Basins will be designed to eliminate impacts of peak flows on downstream treatment processes and prevent flows from exceeding the capacity of the effluent force main during peak storm events.

Flow to the equalization basin will be screened and degrittled raw influent that gravity flows from the Headworks. As shown on the Liquid Process Flow Diagram in Section 6.1, a motorized throttling

valve and flow meter (Mag Meter #2) will be provided to automatically control the flow rate to the downstream treatment process by diverting flows in excess of an operator selected value into Wet Weather Tank #1. The flow to the treatment process will be calculated by the control system as the difference between the values transmitted from the meter downstream of the Influent Pump Station (Mag Meter #1) and the meter on the line to the EQ Basin (Mag Meter #2).

Flows will enter and exit the Wet Weather Tank #1 through an 18-in pipe, which will be valved in the yard allowing it to act as an influent and effluent line. A motorized gate will be installed in the wall separating Wet Weather Tank #1 and Wet Weather Tank #2. This gate will allow operators to direct flow into Wet Weather Tank #2 if the volume of a peak flow event exceeds the storage capacity of Wet Weather Tank #1. In addition, emergency overflow weirs in the walls separating the two carrousel will be provided as a backup for the motorized gate.

The evaluation of the plant hydraulics for sizing of the EQ Basins was performed in a separate memo titled *Peak Flow Equalization and Discharge* and included in the RRR WWTP Master Plan in February 2015. From that analysis it was determined that at least 1.5 MG of storage would be required for a plant flow of 8 mgd (AA, 20 mgd PH) to limit peak day flows through the process to 13.0 MGD. For flow conditions beyond the 8.0 MGD expansion, an additional 1.5 MG of storage volume will be required to limit peak flows through the expected service life of the existing 24-inch diameter effluent force main.

Wet Weather Tank #1 and #2, total volume of 3.5 MG, will be used to satisfy the additional storage volume required for the 9.2 mgd (AA, 23 mgd PH) plant flow and for conditions beyond the 9.2 MGD expansion.

Mixing for the Wet Weather Tank #1 will be accomplished using a jet mixing system. This system will pump the stored wastewater through a header with nozzles canted upward and downward at approximately 45 degree angles to create “jets” to keep solids suspended.

Following a peak flow event, the stored wastewater will be drained through an 18-in gravity line back to the Influent Pump Station. The drain line from Wet Weather Tank #1 will be valved in order for it to act as an influent and effluent line. The valve on the effluent portion of the line will be normally closed so that influent flows from the Headworks do not divert into the effluent piping that returns the stored wastewater to the IPS. When the stored wastewater needs to be drained back to the IPS, the valve on influent portion of the pipe will be closed. A motorized throttling valve and flow meter (Mag Meter #3) will be provided to control the flow rate to the IPS and return flow to the treatment process at a fairly constant rate. The rate of flow return will be an operator-selected value. Some of the flow meters and throttling valves will be below grade level in a vault while others will be located above grade.

As stated earlier, Wet Weather Tank #2 will normally be empty. Therefore, after a peak event, once it is drained, it will be necessary to wash the tank down to prevent odors. Water cannons mounted on support stands, as well as, hydrants and hose racks will be provided to facilitate the wash down operation.

See the table below for additional information.



**Table 5-6 Equalization Basins**

DESCRIPTION	DESIGN CRITERIA
Quantity	2
Tag Designation	Wet Weather Tank #1, Wet Weather Tank #2
Type	Carrousel; Existing Aeration Basin Retrofit
Basin Dimensions, ft	184 x 111.5 (outside to outside of each carrousel)
Basin Area, sq. ft each	17,890
SWD, ft	13.5
Basin Volume, MG each	1.75
Min Depth for Mixing	None
Usable Storage Volume	Full Volume
Design Maximum Fill Rate, mgd	15, Peak day flow rate
MIXING SYSTEM	
Type	Jet Mixing
Manufacturers	Fluidyne Corporation, Evoqua, KLA Systems, Inc.
Header pipes per Pump	1 with 3 smaller branches
Header pipe, in	16-20
Nozzles per header pipe	Vary per manufacturer
All piping/support material	304SS
Number of mixing Pumps	2, 1 per basin
Min. Impeller Diameter, in	16
Min Motor, hp	45

## 5.8 ANOXIC DISTRIBUTION BOX

An anoxic distribution box containing weirs will be provided ahead of the anoxic basins to split flow evenly to each of the anoxic basins. The box will be designed to split flow to four anoxic basins. Directly upstream of the distribution box an anoxic mixing chimney will be constructed to completely mix the raw water from the headworks, return activated sludge, decant from the sludge holding tanks and filtrate from dewatering. The mixing chimney includes two chambers with all flow entering the first box then passing over a baffle wall prior to entering the second chamber. Then the flow passes through boxouts at the base of a second baffle wall to enter the anoxic distribution box. All chambers were designed to maintain a minimum flow rate of 0.5 ft/s at minimum flow conditions. Both baffle walls within the mixing chimney will be designed to allow

for scum to pass through to the downstream processes. The design criteria for the anoxic distribution box are shown below in Table 5-7.

**Table 5-7 Anoxic Distribution Box**

DESCRIPTION	DESIGN CRITERIA
Quantity	1
Weir length, ft	6
Weir Quantity	4
Distribution Box Area, sqft	128
Length, ft	16
Width, ft	8
Side Water Depth at Average Flow, ft	22.58
Shutoff type	Downward opening weir gates

## 5.9 ANOXIC/AERATION BASINS

To achieve the necessary aeration capacity for year-round complete nitrification, the WWTP process is being converted to a fine bubble diffused aeration activated sludge process. Three new anoxic/aeration basin trains will be constructed, each including one anoxic basin and one aeration basin (zone 1, -2, -3) with a 20-ft SWD, 2.25 MG volume, and a floor elevation at 4.33 ft-NAVD88. Existing grade at the location of the new anoxic/aeration basins is  $\pm 9.0$ . Anoxic Basins will be constructed at the start of the each anoxic/aeration basin. The existing anoxic basins will be repurposed as additional sludge storage, Sludge Storage Tank #3.

Influent flow to the anoxic/aeration basins results from a 42-in. raw wastewater pipe from the Headworks and 30-in. return activated sludge piping from RAS/WAS Pump Station #1 and #2. These flows will combine in a 16-ft x 8-ft anoxic mixing chimney where they will travel around two baffle walls before entering the anoxic distribution structure. From the anoxic distribution structure, flow is diverted through four six-foot wide downward opening gates and two 42-in. ductile iron pipes into four anoxic mixing chimneys. The downward opening gates will act as weirs that are adjustable so plant personnel can obtain desired influent flow in each anoxic/aeration basin or used to close off flow to a particular basin for maintenance. After exiting the four anoxic mixing chimneys, flow travels through the anoxic basins before entering the aeration basins.

A large bubble mixing system (BioMix) will be provided for anoxic basins 1-3 to keep the solids suspended. Two compressors, one duty and one standby, will serve anoxic basins 1-3. Two compressed air receivers and two valve panels will be used for the anoxic basin mixing system. One air receiver and valve panel will be located on the walkway between anoxic basins 1 and 2 at the north end of the basin and similarly, the other set will be located on the walkway between anoxic basin 3 and future 4. See Table 5-8 below for additional design criteria on the anoxic basins and the Enviromix system.

**Table 5-8 Anoxic Basins**

DESCRIPTION	DESIGN CRITERIA
Anoxic Cells per Train	1
Tag Designation	Anoxic Basins 1, -2, -3
Basin Dimensions, ft	61 x 17.5 (inside to inside per anoxic basin)
Basin Area, sq ft	1,070/basin
SWD, ft	20
Mixing Chimney Dimensions, ft	8 x 8 (inside to inside, 1 per anoxic basin)
Total Unit Basin Volume, gal	160,100
Total Basin Volume, gal	480,300
MIXING SYSTEM	
Type	Large Bubble
Manufacturer	Enviromix
Header pipe, in	2
Header pipes/basin	2 @ ±60 ft in length
Nozzles/header	8
Total Number of Nozzles, Total per Basin (Current/Future)	48/64
Valve Panels	2 – 304SS 6 valve panels
Rotary Screw Compressor	2 – 15 HP Atlas Copco, Model GA11VSD+
Available Pressure at VP, psig	100
Capacity per basin, acfm	16
Vertical Receivers	2 – 120 gal each

Once in the aeration basin, flow travels through three oxic zones (Zone 1, -2, -3) before entering the common effluent channel. From the common effluent channel, 42-in. mixed liquor piping sends the effluent from the anoxic/aeration basins to the secondary clarifier splitter box. See Table 5-9 below for additional design criteria on the aeration basins.

**Table 5-9 Aeration Basins**

DESCRIPTION	DESIGN CRITERIA
Quantity	3
Tag Designation	Aeration Basin 1, -2, -3
Type	9-in. Fine Bubble Membrane Diffused Aeration

DESCRIPTION	DESIGN CRITERIA
SWD	20 ft
Diffuser Submergence	19 ft
Unit Basin Volume	2.21 MG (6.625 MG, total)
Number of Zones per basin	3
Oxic Zone Designation	Zone 2, -3, -4
Volume per zone	0.74 MG
Maximum Month MLSS	2,550 mg/L
Annual Average MLSS	1,250 mg/L
Max Month Aerobic SRT	7.2 days
Annual Average Aerobic SRT	5.0 days
Max Month MLSS Anoxic Selector HRT	1.08 h
Annual Average Anoxic Selector HRT	1.25 h
Anoxic Selector F:M Max Month	2.8 lb BOD/lb MLSS/d
Anoxic Selector F:M Annual Average	3.5 lb BOD/lb MLSS/d
MLSS Recycle	21.2 MGD

Table 5-10 provides the details of the new diffused aeration system that will be installed in the three aeration basins to transfer oxygen to the mixed liquor. Process air demands are summarized for various scenarios.

**Table 5-10 Diffused Aeration System**

CONDITION	TOTAL FOR ALL 3 AERATION BASINS COMBINED			
	ZONE 1	ZONE 2	ZONE 3	TOTAL
Total number of diffusers	2065	912	649	3626
Type of diffusers	Fine-pore Membrane 9 inch disks			
Residual Dissolved O2 Average, mg/L	2	2	1.5	-
Residual Dissolved O2 Peak, mg/L	1	1	1	-
PROCESS AIR REQUIREMENT (SCFM)				
Maximum Month Summer	6,200	2,740	1,950	10,890
Maximum Month Summer with 10% Safety Factor <sup>1</sup>	6,820	3,010	2,150	11,980
Peak Day Summer	6,470	2,860	2,220	11,550
Peak Day Summer with 10% Safety Factor <sup>1</sup>	7,110	3,140	2,440	12,690

CONDITION	TOTAL FOR ALL 3 AERATION BASINS COMBINED			
Annual Average at Average Temperature	2,840	1,810	1,110	5,760
Diurnal Minimum Airflow	1,650	1,050	650	3,350
Mixing Air <sup>2</sup> (5 scfm/kcf)	1,480	1,480	1,480	4,440
<sup>1</sup> Includes safety factor for diffuser fouling. <sup>2</sup> Install control functionality to periodically open up the aeration control valves and provide a higher airflow for a short period of time to provide mixing energy when process air falls below mixing air.				

Mixed liquor is continuously recirculated from oxic zone 3 to the mixing chambers at the start of the anoxic basins by a single, submersible propeller-type pump located at the end of each anoxic/aeration basin train. The pumps are rated at 6.1 mgd at 1.9 feet of head. The total recirculation capacity is 21.2 mgd, or 200 percent of the maximum month flow of 10.6 mgd. Mixed Liquor recirculation pumping is summarized below in Table 5-11.

**Table 5-11 Mixed Liquor Return Pumps**

DESCRIPTION	DESIGN CRITERIA
Number of pumps	3 (one per basin train)
Type	Submersible, propeller
Tag Designation	Mixed Liquor Recycle Pump 1, -2, -3
Manufacturer	Flygt, ABS, KSB
Capacity at 2.9 foot TDH	4,900 gpm (7.1 mgd each), 21.2 mgd total
Motor, hp	6-8
Drive Type	Adjustable Speed
Control	Automatic programmable (PCS)
Recirculation ratio at 10.6 mgd maximum month flow	200%

## 5.10 AERATION BLOWERS

The new fine bubble diffused aeration system requires the addition of new aeration blowers, air distribution piping, and membrane diffusers to transfer oxygen into the mixed liquor. Gearless single-stage centrifugal turbo blowers, located in the new blower and dewatering building, will supply air to the biological process. This process air will be metered by thermal dispersion flow meters and controlled via motor operated valves to achieve desired process dissolved oxygen content. The blower speed will be drive by discharge pressure. The process air demands are listed in Table 5-12.

A three duty blower configuration was selected with space allocated for a fourth future blower. The new aeration blowers will be installed with the capacity to meet the total maximum month summer

airflow with 10% safety factor, 12,000 scfm, with one blower out of service. The peak day airflows will be achieved with the third blower. The design criteria of the new blowers are summarized below.

**Table 5-12 Aeration Blowers Design Criteria**

DESCRIPTION	DESIGN CRITERIA
Blower Type	Gearless single-stage centrifugal turbo
Manufacturers	APG-Neuros, Sulzer
Configuration	3 duty + 1 future
Dimensions, in	85x65x80
Discharge Pressure, psig	10.5
Rated Airflow, per blower, scfm	6,000
Blower turndown (summer), scfm	~3,000
Blower turndown (winter), scfm	~3,250
Firm Capacity, scfm	12,000
Total Installed Capacity, scfm	18,000
Bearing Type	Non-contact magnetic or air, manufacturer dependent
Metal-to-metal contact	None
Lubrication	None
Motor Size, hp	375
Input power, volts/phase/frequency	480/3/60
Operating Speed, rpm	Up to 14,000
Motor cooling	Air or Glycol, manufacturer dependent
Noise (free-field), dBa	<85
Drive Type	Integral Variable Frequency Drive for High Speed Motor
Motor Type	Permanent Magnet
Control	LCP & MCP

Each blower will have an individual suction which will include a side-outlet high-flow synthetic cartridge type filter. The blowers will discharge into a common 30-in. header that distributes air to the aeration basins through an automated control strategy. The blower inlet piping will be stainless steel 304L. Buried aeration pipe will be stainless steel 316L and above grade discharge piping will be coated carbon steel. Pipe above grade will be schedule 10s and buried pipe will be schedule 40s. Insulating flange kits will be used to prevent contact of dissimilar pipe metals. Each blower will have an individual blowoff used for startup, shutdown, and depending on the blower manufacturer,

surge mitigation. Each individual blowoff will have a silencer and will discharge directly into the blower room.

### 5.11 BLOWER ROOM

A new blower room will be provided to house the aeration blowers for the new aeration basins. The blower room will be located in a building that also houses an electrical room and the dewatering room. The blower room floor level will be constructed at EL 14.08 ft-NAVD88 in order to be one foot above the base flood elevation. The floor level will be approximately four feet above the surrounding grade. A loading dock will be provided for access to the room for equipment removal. The scope for the new blower room is as follows:

- Aeration basin blowers and mixing compressors will be located in the blower room.
- The aeration control system MCP and the electrical components will be located in the electrical room.
- Earthquake drain supported structure.
- Slab on grade elevated to floor elevation of 14.08 ft-NAVD88.
- HVAC dedicated to the blower room to achieve circulation across the equipment.
- Blowers will be moved with jacks or forklifts.
- The layout is design for a future blower.
- Blowers will have a 2x2 arrangement to maximize space.
- One rolling aluminum door for forklift access into the blower room.

### 5.12 SECONDARY CLARIFIERS

With the addition of aeration volume, aeration basins can be operated at lower MLSS. This allows more flow to be treated with the three existing 75-foot clarifiers, since solids loading rate on the clarifiers was the limiting criteria. Stress testing results conducted by MPW on 6/22/2017 – 6/23/2017 indicated that the clarifiers can take higher solids loading rate compared to typical design of 25 lbs/d/ft<sup>2</sup>. It is recommended that stress testing be repeated during winter season to confirm results. At maximum month flow of 10.6 mgd and MLSS of 2550 mg/L at maximum month winter conditions, solids loading rate on the clarifiers will be 33.9 lbs/d/ft<sup>2</sup> with 100% RAS and all clarifiers in service. The clarifiers will be able to handle a peak day flow of 16.6 mgd with all clarifiers in service. The secondary clarifier sizing, equipment, and capacity information is summarized in Table 5-13. With the largest flow capacity unit out of service, the remaining units will be able to treat in excess of 50 percent of annual average design flow as described in the Reliability Classification III in Table 2-1.

**Table 5-13 Secondary Clarifiers**

DESCRIPTION	DESIGN CRITERIA
Quantity <sup>1</sup>	3
Diameter	75 ft
Unit Surface area	4,418 ft <sup>2</sup> (13,254 ft <sup>2</sup> , total)
Side Water Depth	16 ft
Sludge collection equipment	USFilter/Envirex Tow-bro rapid sludge withdrawal 0.5 hp constant speed drive
Surface Overflow Rate at 9.2 mgd Annual Average	695 gal/ ft <sup>2</sup> /day
Surface Overflow Rate at 10.6 mgd Maximum Month	800 gal/ ft <sup>2</sup> /day
Surface Overflow Rate at 16.6 mgd Peak Day	1250 gal/ ft <sup>2</sup> /day
Solids Loading Rate at 9.2 mgd Annual Average (at 9.2 mgd RAS)	14.2 lbs/ft <sup>2</sup> /day
Solids Loading Rate at 10.6 mgd Maximum Month (at 10.6 mgd RAS)	33.9 lbs/ft <sup>2</sup> /day
Solids Loading Rate at 16.6 mgd Peak Day (at 10.6 mgd RAS)	43.5 lbs/ft <sup>2</sup> /day
<sup>1</sup> With one unit out of service, the remaining units will be able to treat in excess of 50 percent of annual average design flow as described in Reliability Classification III	

### 5.12.1 Secondary Clarifier Splitter Box

Due to increases in the hydraulic conditions for the maximum month flow of 10.6 mgd (9.2 mgd AA), modifications will be made to the secondary clarifier splitter box that include the following:

- Increase top of splitter box wall to elevation of 21.00 ft.
- Addition of 8 aluminum trough finger weirs ( 2 in each section of the 4 splitter box sections)
- Adjustments made to existing gates, stairs, and grating to accommodate for the increase in structure elevation.

Mixed liquor will flow from the clarifier splitter box to the three secondary clarifiers via 24-in. pipes.

Clarified effluent will be conveyed in 24-in. pipes to the chlorine contact basins for disinfection. RAS/WAS from Secondary Clarifiers #1 and #2 will be directed in 18-in. pipes to the RAS/WAS PS#1 and RAS/WAS from Secondary Clarifier #3 and future Secondary Clarifier #4 will be directed in 18-in. pipes to RAS/WAS PS#2. Scum from the secondary clarifiers will be sent to the scum tanks before being conveyed to WAS storage.



### 5.13 RAS PUMPING

To provide the capability to operate under a number of loading and settleability conditions, Return Activated Sludge (RAS) pumping capacity will need to be increased from the current 5.3 mgd to 10.6 mgd, or 100 percent of maximum month flow for the expanded facility. The two existing 2.3 mgd pumps at in RAS Pump Station #1 will be replaced with 3.5 mgd pumps. The existing 1.5 mgd pump will be replaced with a 3.5 mgd pump to provide a firm capacity of 7.1 mgd. One existing 1.5 mgd pump in RAS Pump Station #2 will be replaced with a 3.5 mgd pump. An additional 3.5 mgd pump will be added. The other existing 1.5 mgd remains to provide a firm capacity of 5.0 mgd, bringing the total firm capacity to 12.1 mgd.

**Table 5-14 RAS Pumping**

DESCRIPTION	DESIGN CRITERIA
Quantity	3 Pumps, RAS/WAS Pump Station #1 2 Pumps, RAS/WAS Pump Station #2
Type	Submersible
RAS Pumping Station 1	3 pumps with 3.5 mgd @ 34 ft TDH
RAS Pumping Station 1, firm capacity	7.1 mgd (with one 3.5 mgd pump out of service)
RAS Pumping Station 2	2 pumps with 3.5 mgd @ 34 ft TDH, each
RAS Pumping Station 2, firm capacity	5.0 mgd (with one 3.5 mgd pump out of service)
Total Firm capacity	12.1 mgd
Firm Capacity as a Percentage of Maximum Monthly flow	114% (of 10.6 mgd)

### 5.14 WAS PUMPING

Each RAS/WAS pumping station listed in the section above has two submersible WAS pumps, one duty and one standby. Based on the rated pump capacities shown in the table below, existing WAS pumping capacity is adequate. Flow from WAS Pump Stations 1 and 2 will be directed to Sludge Storage Tanks #1-3.

**Table 5-15 WAS Pumping**

DESCRIPTION	DESIGN CRITERIA
Quantity	2 Per Pumping station, 4 Total
Rated capacity	288,000 gal/day, each pump, @ 33.5 ft TDH
Annual average WAS load at 9.2 mgd flow	12,100 lbs/d
Maximum monthly WAS load at 10.6 mgd	18,200 lbs/d
WAS solids concentration assumed	0.75%

DESCRIPTION	DESIGN CRITERIA
WAS flow at 9.2 mgd Annual Average flow	193,900 gal/d
WAS flow at 10.6 mgd Maximum Monthly flow	290,900 gal/d

## 5.15 DISINFECTION

### 5.15.1 Chlorine Contact Basins

Effluent disinfection is achieved at RRRWWTP by using sodium hypochlorite. This facility currently has two chlorine contact chambers with a total volume of 125,000 gallons. In order to achieve the recommended chlorine contact times of 30 minutes and 15 minutes at the annual average (AA) and peak hour (PH) flows, respectively, an additional contact basin is required. It is recommended that the existing contact basins be modified to combine them into a single chamber and one additional contact chamber be constructed. Each chamber will have approximately 137,000 gallons of volume which will provide sufficient contact time for the annual average flow of 10 mgd and the peak hour flow of 25 mgd. See the following table for contact times at average and peak flows.

**Table 5-16 Disinfection**

DESCRIPTION	DESIGN CRITERIA
Number of Chlorine Contact Chambers	2 (modified existing, 1 new)
Chamber 1 volume, gal	137,000
Chamber 2 volume, gal	137,000
Contact time at 9.2 mgd annual average flow	37 min
Contact time at 25 mgd peak day flow	15.5 min

The new serpentine style contact chamber will include three baffle walls to produce a flow path approximately 290 feet in length. The channel width will be 8 ft wide resulting in a length-to-width (L/W) ratio of 37, within acceptable range of the preferred value of 40, which will aid in minimizing hydraulic dead zones in the chamber. The chamber will have a top of wall elevation of 14.13 ft and an average basin floor elevation of 3.1 ft. The basin floor will be sloped to a 1.5 ft wide by 1 ft deep drainage trench with two 8 in. mud valves for drainage of the basin. These basin drainage pipes will connect to the existing 10 in. drainage line discharging to the plant drainage pump station.

Water surface elevations (WSEL) for AA and PH flows are expected to be 11.19 ft and 11.63 ft, respectively, resulting in a water depth within the chambers ranging from 7.8 to 8.6 ft. Horizontal velocities in the new chamber will range from 7.9 ft/min to 18.9 ft/min (AA and PH flows, respectively), minimizing settlement potential of any solids in the basin.

The existing contact basins will be modified to create a single basin and utilize flow exiting the slide gate on the eastern side of the contact basin influent splitter box. The new basin will be fed from the existing slide gate on the western side of the splitter box. The existing sodium hypochlorite

injection points at the influent splitter box Water Champ and in the secondary clarifier effluent line will remain as backup dosing locations and a new dosing point will be installed at each of the three secondary clarifier effluent chambers. While the intent is to utilize a single dosing point during normal operations, this will allow for redundancy as clarifiers are taken out of service for maintenance. Placing the new injection points at the clarifiers will allow for visual inspection and easier access for routine maintenance of the above grade sodium hypochlorite piping. The turbulent clarifier outfall will aid in mixing of the sodium hypochlorite and the secondary clarifier effluent pipe will provide additional contact time for disinfection. Each basin will include an adjustable effluent weir gate and ultrasonic level sensors for flow monitoring and control.

To account for the additional capacity the existing effluent weir will be lengthened and three new weirs will be constructed in the effluent channel adjacent to the existing effluent weir. Each weir will be 5.75 ft wide for a total of 23 ft of weir capacity. The effluent from both basins will be combined within the effluent channel for composite sampling before overflowing the weirs and discharging into the effluent plumping station wetwell.

### 5.15.2 Sodium Hypochlorite Storage and Feed system

The existing sodium hypochlorite storage and feed system will be provided with new feed equipment to feed chemical to the following injection points:

- Secondary Clarifier Effluent No. 1, 2 and 3 (3 new injection points – not simultaneous)
- Discharge of Service Water Pumps (new)

The sodium hypochlorite system consists of one existing fiberglass reinforced plastic (FRP) bulk storage tank for bulk sodium hypochlorite delivery and storage installed in place of the existing caustic scrubber, and three existing FRP dilution tanks installed in the existing chlorination building. 12.5% Trade sodium hypochlorite is delivered and stored in the bulk storage tank. Two existing peristaltic hose transfer pumps deliver solution from the bulk tank to the dilution tanks where the 12.5% Trade sodium hypochlorite is diluted down to 6% Trade solution. Spill containment is provided for all chemical storage. Currently three installed peristaltic hose metering pumps (two duty, one standby) convey the solution from the dilution tanks to existing Chlorine Contact Basins (CCB) No. 1 and 2 combined feed point. Sodium hypochlorite is fed to the chlorine contact basins continuously via one of two existing dosing points. The first dosing point introduces the sodium hypochlorite solution in to the chlorine contact basins splitter box via a Water Champ. The second dosing point injects the solution into the 36-in. secondary effluent combined piping immediately upstream of the chlorine contact splitter box. To further improve dosing flexibility, mixing and retention time, three additional dosing point will be included farther upstream, one at each of the secondary clarifier effluent chambers. Injection of sodium hypochlorite to the two existing and three new injection points will not be done simultaneously. Therefore, dedicated metering pumps for each injection point is not required. Separate feed piping will be provided with valves to utilize or isolate the various injection points.

The existing CCB No. 1 and 2 will be modified and an additional basin constructed to accommodate for the new CCB capacity. Therefore, metering pumps will be sized to treat the new combined flow for the CCB through the influent chamber. It is recommended that the existing peristaltic hose metering pumps be replaced with new peristaltic tube pumps with higher turndown capacity in

order to minimize the total number of pumps required to feed the increased flow rate through the CCB influent chamber. The new pumps will be installed in place of the existing pumps in the existing chlorination building as shown on drawings. It will be determined if the existing sodium hypochlorite pump discharge piping to the injection point is sufficient for the new combined flow rates. New piping will be provided as necessary.

Additionally, sodium hypochlorite will be fed to the service water pump discharge header to prevent biological fouling of the service water pipeline. Two new metering pumps will be provided to feed sodium hypochlorite to the service water pumps discharge header. Pressure at the discharge of the service water pumps can be as high as 90 psi. This high pressure can significantly reduce peristaltic pump tube life. Therefore, hydraulic diaphragm metering pumps will be provided for this feed point. CPVC piping and valves will be provided on the pump discharge to the injection point due to the high pressure. The metering pumps for this feed point will be installed in the available space in the existing chlorination building adjacent to the dilution tanks. This will reduce the length of suction piping to the pumps. The above grade piping at each dosing point will include encasement or coatings for UV protection and to minimize thermal transfer to the CPVC carrier pipe. The system is designed to operate at a maximum concentration of 12.5%

No changes will be made to the existing storage or dilution equipment. New chemical feed equipment will be designed and sized based on the following criteria:

- The metering pumps will be sized for the full range of expected chemical feed rates corresponding to minimum to maximum plant flows and minimum to maximum chemical dosages.
- All chemicals will be fed directly from the dilution storage tanks.
- Chemical feed rates will be controlled and adjusted automatically proportional to plant flow. Other control strategies will be implemented such as chlorine residual or pH trimming where appropriate.
- Chemical metering pumps will be provided with local and remote control.
- Existing piping will be replaced as necessary and new piping will be provided to feed to the feed point.
- All exposed piping will be insulated.

Sodium hypochlorite will degrade over time, so sizing of feed equipment will be based on the estimated degraded concentration.

**Table 5-17 Sodium Hypochlorite Disinfection System Design Information**

DESCRIPTION	DESIGN CRITERIA
Delivered Chemical	12.5% (trade) sodium hypochlorite, 10.6% as chlorine, SG = 1.175, Density = 9.8 lbs/gal
Fed Chemical	6% (trade) sodium hypochlorite, 5.51% as chlorine, SG = 1.089, Density = 9.08 lbs/gal

DESCRIPTION	DESIGN CRITERIA
Operating Conditions	24 hours per day 7 days per week 30 days per month
Application Point (s)	Chlorine Contact Basins Influent
<b>PLANT FLOW, MGD, TOTAL (CHLORINE CONTACT BASINS NO. 1, 2 )</b>	
Minimum	4.2
Average	10.2
Maximum	26
<b>CHEMICAL DOSAGE, MG/L AS 100% CHLORINE</b>	
Minimum	1.2
Average	5
Maximum	8
<b>TOTAL CHEMICAL FEED RATES, LBS/DAY OF 100% CHLORINE</b>	
At min flow/ min dose	42
At avg flow/ avg dose	417
At max flow/ max dose	1,736
<b>TOTAL CHEMICAL FEED RATES, GPH OF 12.5% (TRADE) NAOCL DELIVERED SOLUTION</b>	
At min flow/ min dose	1.68
At avg flow/ avg dose	16.7
At max flow/ max dose	69.3
<b>TOTAL CHEMICAL FEED RATES, GPH OF 6% (TRADE) NAOCL DILUTED SOLUTION</b>	
At min flow/ min dose	3.50
At avg flow/ avg dose	34.7
At max flow/ max dose	144
Application Point (s)	Service Water Pumps Discharge
<b>PLANT FLOW, MGD (GPM)</b>	
Minimum	0.36 (250)
Average	0.72 (500)
Maximum	1.87 (1300)

DESCRIPTION	DESIGN CRITERIA
<b>CHEMICAL DOSAGE, MG/L AS 100% CHLORINE</b>	
Minimum	1
Average	2
Maximum	4
<b>CHEMICAL FEED RATES, LBS/DAY OF 100% CHLORINE</b>	
At min flow/ min dose	3.00
At avg flow/ avg dose	12.0
At max flow/ max dose	62.5
<b>CHEMICAL FEED RATES, GPH OF 12.5% (TRADE) NAOCL DELIVERED SOLUTION</b>	
At min flow/ min dose	0.12
At avg flow/ avg dose	0.48
At max flow/ max dose	2.50
<b>CHEMICAL FEED RATES, GPH OF 6% (TRADE) NAOCL DILUTED SOLUTION</b>	
At min flow/ min dose	0.25
At avg flow/ avg dose	1.00
At max flow/ max dose	5.20
<b>EXISTING BULK CHEMICAL STORAGE - 12.5% (TRADE) NAOCL DELIVERED SOLUTION</b>	
Tank Orientation	Vertical
Tank Material	Fiberglass Reinforced Plastic (FRP)
Number of Tanks	One (1)
Useable Volume per tank, gallons	5,500
Tank Dimensions	8 ft diameter x 16 ft straight side
<b>DAYS OF STORAGE (CHLORINE CONTACT BASINS ONLY)</b>	
At avg flow/ avg dose	13.7
At max flow/ max dose	3.3
<b>DAYS OF STORAGE (CHLORINE CONTACT TANKS BASINS AND SERVICE WATER PUMP DISCHARGE)</b>	
At avg flow/ avg dose	13.3
At max flow/ max dose	3.2

DESCRIPTION	DESIGN CRITERIA
<b>EXISTING DILUTION CHEMICAL STORAGE - 6% (TRADE) NAOCL DELIVERED SOLUTION</b>	
Tank Orientation	Vertical
Tank Material	Fiberglass Reinforced Plastic (FRP)
Useable Volume per tank, gallons	2,000 each
Tank Dimensions	7 ft diameter x 8 ft straight side
Number of Tanks	3
<b>DAYS OF STORAGE (CHLORINE CONTACT BASINS ONLY)</b>	
At avg flow/ avg dose	7.2
At max flow/ max dose	1.7
<b>DAYS OF STORAGE (CHLORINE CONTACT BASINS AND SERVICE WATER PUMP DISCHARGE)</b>	
At avg flow/ avg dose	7.0
At max flow/ max dose	1.7
<b>TOTAL CHEMICAL STORAGE</b>	
Useable Volume, gallons	11,500
<b>DAYS OF STORAGE (ALL FEED POINTS)</b>	
At avg flow/ avg dose	20.3
At max flow/ max dose	4.9
<b>EXISTING CHEMICAL TRANSFER PUMPS - 12.5% (TRADE) NAOCL SOLUTION</b>	
Pump Type	Peristaltic Hose
Number of Pumps	2 (1 Duty/ 1 Standby)
Pump Capacity, gpm each	75
Single Tank Fill Time, minutes	15
Control	Manual start, manual-automatic stop, constant speed
<b>NEW FEED EQUIPMENT - 6.0% (TRADE) AND 12.5% (TRADE) NAOCL SOLUTION</b>	
Application Point (s)	Chlorine Contact Basins Influent, Secondary Clarifier Effluent
Pump Type	Peristaltic Tube
Total Number of Pumps	3 (2 duty, 1 standby)
Pump Range, gph each	1.68 to 72
Pump Turndown <sup>1</sup>	43:1

DESCRIPTION	DESIGN CRITERIA
Pump Discharge Pressure, psi	30
Pump Control	Manual and automatic speed control
Application Point (s)	Service Water Pumps Discharge
Pump Type	Hydraulic Diaphragm
Total Number of Pumps	2 (1 duty, 1 standby)
Pump Range, gph each	0.12 to 5.20
Pump Turndown <sup>1</sup>	43:1
Pump Discharge Pressure, psi	105
Pump Control	Automatic speed and stroke length control
PIPING	
Hard Piping	Schedule 80 CPVC
Flexible Piping	Reinforced Teflon tubing
Valves	CPVC diaphragm valves as required
Seals/O-rings/Gaskets	Viton and Teflon
1 Pump Tube Size Will Need To Be Manually Changed To Cover The Required Feed Range.	

### 5.16 EFFLUENT DIFFUSER

The existing effluent diffuser was installed by CH2M Hill in 1987 to distribute plant effluents from CSWWTP, RRRWWTP, and two reverse osmosis water treatment plants into the Charleston Harbor at Outfall #005. The diffuser location was located adjacent to Rebellion Reach in a flat region of the harbor bottom in approximately 35 feet of water. This diffuser location was chosen because it was along the proposed outfall alignment, was not within the dredged portion of the Rebellion Reach Channel and was believed to be within the main Rebellion Reach flow. Reference the USGS Map in Section 6.4 for the discharge location for Outfall #005 and the location of Rebellion Reach. The distribution of effluent across the harbor is suggested by SCDHEC as part of their toxic control strategy for wastewater discharges.

The diffuser was designed based on the peak day flow of 25.4 mgd for the future expansion (2030) of RRRWWTP. The pipe diffuser will consist of a pipe installed below the harbor bottom with risers extending 9 feet high and spaced every 30 feet along the diffuser.

Design criteria for the effluent diffuser can be seen in the table below.



**Table 5-18 Effluent Diffuser**

DESCRIPTION	DESIGN CRITERIA
Pipe length, ft	270
Pipe Diameter, in	30
Number of Risers	10 – 12” diameter
Riser Spacing, ft	30
Number of ports/riser	2 (6-in. blind flange with 3-in. orifice eccentrically located at bottom)
Port velocities, ft/s	--

### 5.17 SLUDGE STORAGE

Existing Sludge Storage Tanks #1 and #2 are currently used to store WAS prior to dewatering. The two existing anoxic selector basins will be converted into Sludge Storage Tank #3 to provide the additional volume needed for a minimum of two days of storage capacity based on the maximum month loading condition listed in Table 5-19 Sludge Storage.

The conversion of the anoxic selector basins to Sludge Storage Tank #3 will include the following:

- Demolition of existing concrete walls, mechanical piping, and submersible mixers.
- New submersible Belt Filter Press feed pump with adjustable speed drive and new feed piping.
- New coarse bubble mixing system with stainless steel diffusers and one new positive displacement blower. The new blower will be located in the same building as the existing blowers.
- New telescoping valve. Flow from the floating surface decanter will be directed to Plant Drain PS #2.

The new positive displacement blower will be rotary lobed type. Positive displacement blowers are variable pressure, constant capacity machines. The capacity will be adjustable by varying the blower speed via a blower supplied adjustable frequency drive. The technology uses two parallel rotary lobes rotating in opposite directions to compress the air to meet the discharge pressure requirements for the application. The blowers are packaged with inlet and discharge silencers to reduce pulsations and a sound attenuating enclosure to reduce noise. The inlet will be provided with a cartridge type synthetic filter. The blower package will be fitted with integral manufacturer protection controls.

The following table below shows the storage available in days for varying flow conditions.

**Table 5-19 Sludge Storage**

DESCRIPTION	DESIGN CRITERIA
Quantity	1 tank composed of converted existing anoxic selector basins
Volume, gal	462,000
Dimensions, ft	20 W x 93.5 L x 16.5 D each
Total combined volume, all tanks, gal	836,000
Total usable volume, all tanks, gal	627,000
Total usable sludge storage capacity (all tanks) at 9.2 mgd annual average flow and 1% solids, days	4.33
Total usable sludge storage capacity (all tanks) at 10.6 mgd maximum monthly flow and 1% solids, days	2.88
<b>MIXING SYSTEM</b>	
Type	Coarse Bubble
Quantity and Type of Blowers	1 Rotoray Lobe Positive Displacement, with VFD
Blower capacity, scfm	2000
Rated discharge pressure, psi	8.2
Blower horsepower, hp	150
Air/volume ratio, cfm/ft <sup>3</sup>	30/1000
<b>DECANT</b>	
Quantity and Type	1 - 8" Telescoping Valve
Maximum flow rate, gpm	260
Maximum decant time from maximum operating WSEL to minimum WSEL	60 min
Acceptable Manufacturers	Penn-Troy Manufacturing Inc., Waterman Industries
<b>BELT FILTER PRESS FEED PUMP</b>	
Tag Designation	TWAS-PCH-7301
Quantity and Type	Submersible Chopper Pump with VFD
BFP feed pump capacity	625 gpm at 47 ft TDH; 15 hp

## 5.18 DEWATERING FACILITY (NEW)

The new Blower/Dewatering Building will house two belt filter presses, with space for a future third, in a room located at the south end of the building which also includes rooms for electrical equipment and aeration blowers. The building will be a pre-engineered metal building with metal wall and roof panels. Appropriate protective coatings will be specified to protect the steel from the corrosive elements of the coastal air and the moisture and H<sub>2</sub>S laden environment.

The dewatering room floor level will be constructed at EL 14.08 ft-NAVD88, one foot above the base flood elevation as required by Code. The truck loading bay will be at grade which will be approximately four feet below the floor level. Overhead doors and loading dock type access to those doors will be provided for access to the room for equipment installation/removal. The scope for the new blower room is as follows:

- All dewatering and ancillary systems in one common room.
- Electrical loads served from a shared Electrical Room between attached Dewatering and Blower Rooms .
- PLC for belt filter press control in the Electrical Room. Local control panels with HMI provided at each belt filter press.
- Metal wall and roof panels, insulated with liner panels.
- Slab on grade elevated to floor elevation of 14.08 ft-NAVD88.
- Ventilation for the Dewatering Room to achieve 12 air changes per hour when dewatering is in operation.
- HVAC dedicated to the Electrical Room.
- Two- 2-meter belt filter presses with space for a future press.
- Observation platforms on one side of each belt filter press with maintenance aisle on the opposite side.
- Pump dewatered sludge to the truck loading area.
- Truck loading area consists of one new bay and one future bay. Truck loading area is covered, but not an enclosed space.
- Rolling overhead door for forklift access into the building.

In order to reach the dewatering goals for an 9.2 MGD AA plant, two new belt filter presses will be needed. The following table shows the expected loadings that will be seen in the expansion of the plant using historical data and assuming a 5 day a week, 8 hours a day work schedule.

**Table 5-20 WAS Production Versus Flow**

FLOW (MGD)	WAS PRODUCTION (MM)		WAS DEWATERING						
	lb/day	lb/week	day/wk	lb/day	hr/day	lb/hour	% Feed	gal/day	gpm
6.6	11,200	78,400	5	15,680	8.0	1,960	0.75%	250,679	522
10.6	18,200	127,400	5	25,490	8.0	3,186	0.75%	407,495	849
17.3	29,600	207,200	5	41,400	8.0	5,180	0.75%	662,510	1,380

Two 2-meter belt filter presses will be installed in the new Dewatering Building to meet the solids loading condition identified above for the max. month flow condition of 10.6 mgd. The max. month flow condition 17.3 represents the buildout solids loading condition and will be accommodated with a future expansion of the dewatering building. The design parameters for the two 2-meter belt filter presses are as shown in the following table.

**Table 5-21 Belt Filter Press Design Parameters**

DESCRIPTION	DESIGN CRITERIA
Number of Units	2
Belt Width, meters	2
Polymer consumption (active lbs/ton TS)	18-20
Average Feed Solids, %	0.75
Feed Sludge Type	100% WAS
Volatile Solids, %	80
Max Month Feed Rate, gpm (each)	425
Solids Throughput, lbs/hour (each)	1383
Minimum Solids Capture, %	95
Minimum Cake Consistency, %	16
<b>HOURS OF OPERATION<sup>1</sup></b>	
Two Units at 10.6 mgd Max Month (hours)	8.0
One Unit at 10.6 mgd Max Month (hours)	16.0

The hydraulic and solids loadings listed in the table above are the minimum required capacities based on forecasted plant flows. Because the capacities of belt filter presses are essentially built into the equipment based on the belt width, the capacities of the presses specified will exceed the minimum required capacities in the table by a fairly large amount. The belt filter press suppliers to be listed in the specifications include Alfa Laval Ashbrook Simon-Hartley, Andritz, and BDP. The largest of the three supplier’s equipment footprints and roller maintenance widths have been

accommodated in the design of the building layout. Roller maintenance will be performed using portable gantries for hoisting and moving the rollers inside the building. A bridge crane in the room is not proposed at this time.

In order to take advantage of the capacities available, the design sludge feed rate, polymer system capacities, and cake pumping capacity will be based on the equipment capacities. Based on the equipment capacity provided to Black & Veatch by the manufacturers, the table below shows the minimum required operating hours per day when operated 5 days a week at the solids loading rates for the max month conditions of 10.6 mgd (9.2 mgd AA) and 11.5 mgd (10 mgd AA).

**Table 5-22 Belt Filter Press Capacity Versus Flow**

MAX HYDRAULIC LOADING RATE		WAS DEWATERING HOURS AT 5 DAYS/WEEK			
		10.6 mgd MM		11.5 mgd MM	
gpm	% Feed	lb/day	hr/day	lb/day	hr/day
460	0.75%	25,489	7.4	27,705	8.1

The sludge feed to a given belt filter press will be from a dedicated pump in a sludge storage tank as selected by the operator through the SCADA system. As currently proposed, with three (3) sludge storage tanks and two presses, only two of the three sludge feed pumps can be used to send sludge to dewatering at any given time. In the future, there will be four sludge feed pumps and three presses, and only three of the four sludge feed pumps can be used to send sludge to dewatering at any given time.

Each press will have a dedicated blender/feeder and tote for polymer addition in the sludge feed line inside the room. Polymer will be fed from totes that are moved into/out of the building through the overhead doors via forklift. Totes will be moved on inside of the building via hand truck or pallet jack. A bridge crane in the room is not proposed at this time. A spill containment sump covered with grating will be provided at the polymer system area.

Pressures in cake pumping systems can get relatively high and therefore measures have been taken to ensure that the pressures created by the progressing cavity cake pumps are not excessive. The cake pump discharge from a given pump will be through a dedicated line to the screw conveyor at the truck loading bay. Each pump will have its own discharge that is separate from the other pump discharge lines. The quantity of fittings has been minimized and 45 degree bends are used in place of 90 degree bends where practical and long radius bends are used in lieu of short radius bends. Provisions will be made in the design to accommodate the installation of lubrication rings in the future to allow additional reduction in discharge pressures if desired. The cake discharge piping will be Class 53 ductile iron with grooved end fittings and ceramic epoxy lining.

The progressing cavity cake pumps can be relatively long, especially if the discharge pressures are high. It is good practice to limit the pressure developed by the pump to 50 psi per stage of the rotor/stator components. The discharge pressures for cake pumps at the two presses being installed initially are expected to be up to 100 psi and therefore they will have 2 stage pumps. The length needed to accommodate these pumps including the maintenance length to remove/install

the rotor/stator is close to 17 feet. Due to the length of the cake discharge piping from the future third press to the future second truck loading bay, a 4 stage cake pump will be required. Therefore, the length needed to accommodate this pump and the maintenance length to remove/install the rotor/stator is close to 20 feet. The cake pump suppliers to be listed in the specifications include Moyno, Netzsch, and Seepex.

The number of hours required to fill a truck with cake are shown in the table below for plant flow rates of 9.2 mgd AA and 10 mgd AA, and the associated maximum month conditions.

**Table 5-23 Truck Loading Times Versus Flow**

FLOW	WAS DEWATERING <sup>(1)</sup>		CAKE LOADING			
	lb/day	lb/hr	% Solids	gpm	lb/hour	hours/truck <sup>(2)</sup>
9.2 AA	14,700	1,838	16	27	14,045	2.54
10.6 MM	25,489	2,748	16	40	21,068	1.69
10.0 AA	18,470	2,309	16	29	15,266	2.33
11.5 MM	27,705	3,463	16	43	22,732	1.57

Notes  
 1. Assumes dewatering rates based on 5 days a week, 8 hours a day  
 2. Assumes truck capacity of 20 cubic yards and 37,000 pounds of cake

### 5.18.1 Polymer Storage and Feed system

Equipment for the dewatering polymer storage and feed system, utilized for sludge dewatering, will be installed to feed polymer at the following point:

- Sludge Feed Line to Belt Filter No.1.
- Sludge Feed Line to Belt Filter No.2.

The initial system will consist of the following equipment:

- Total of two storage totes (one tote, scale and mixer connected to feed to each belt filter press). Space provided to store an additional tote for the future belt filter press.
- Two polymer feeder/blenders (one dedicated to each belt filter press). Space provided to install an additional feeder/blender for the future belt filter press.

The dewatering polymer system will be located indoors in the Dewatering Facility.

Polymer will be delivered to the plant in 400 gallon totes. A total of two totes will be provided. One tote will be connected and dedicated to each feeder/blender. Polymer level within the tote will be monitored by a weigh scale. Polymer feeder/blender will be provided to feed neat polymer from the storage tote to the activation chamber. From the polymer feeder/blender the activated polymer will be fed directly to the application point. Space is allocated for one additional feeder/blender and

tote to be installed with the future belt filter press when the plant expands. Piping and isolation valves are provided to allow feeding chemical from either one of the totes.

The preliminary design basis and approximate equipment capacities for the dewatering polymer system are listed in the table below.

**Table 5-24 Dewatering Polymer System Design Information**

DESCRIPTION	DESIGN CRITERIA
Delivered Chemical	35% Active Liquid Polymer Density 8.51 lb/gal
Fed Chemical	0.5% v/v activated polymer solution
Operating Conditions	8 hours per day 5 days per week 20 days per month
Application Point (s)	Sludge Feed Line to Belt Filter No.1. Sludge Feed Line to Belt Filter No.2.
<b>BELT FILTER PRESS SOLIDS FLOW, PPH, each</b>	
Minimum	N/A
Average	1314
Maximum	2251
<b>CHEMICAL DOSAGE, LBS OF ACTIVE POLYMER/ TONS OF SOLIDS</b>	
Minimum	N/A
Average	18
Maximum	20
<b>CHEMICAL FEED RATES, GPH OF NEAT (DELIVERED)</b>	
At min flow/ min dose	-
At avg flow/ avg dose	3.91
At max flow/ max dose	8.69
<b>DILUTED CHEMICAL FEED RATE, GPH OF 0.5%V/V POLYMER SOLUTION</b>	
At min flow/ min dose	-
At avg flow/ avg dose	782
At max flow/ max dose	1738
<b>CHEMICAL STORAGE</b>	
Tank	Tote

DESCRIPTION	DESIGN CRITERIA
Quantity	Two (1 per belt filter press)
Useable capacity, gallons, each	400
<b>DAYS OF STORAGE (calendar days based on actual run times) – per Belt Filter Press</b>	
At avg flow/ avg dose	13
At max flow/ max dose	5.7
<b>POLYMER PREPARATION AND FEED EQUIPMENT</b>	
Type	Feeder/Blender Skid
Equipment	Neat polymer metering pump, activation chamber, and water appurtenances
Quantity	Two (1 per Belt Filter Press)
Dilution Water	
Solution concentration, by % volume	0.5
Flow per Polymer Feeder/Blender, gpm	29.0
Total flow, gpm	58.0
Metering Pumps (Supplied on Polymer Feeder/Blenders)	
Type	Progressive Cavity
Quantity	Two (1 per feeder/blender)
Capacity, gph	0.869 to 8.69
Required turndown	10:1
Control	Flow-paced Manual and automatic start/ stop Manual and automatic speed control
<b>PIPING</b>	
Hard Piping	Schedule 80 PVC
Valves	PVC ball or butterfly valves as required
Seals/O-rings/Gaskets	Viton



## 5.19 STORAGE FACILITY (EXISTING DEWATERING BUILDING)

The existing dewatering building will be retrofitted to accommodate storage of materials.

The scope for the Storage Facility will include the following;

- Removal of existing dewatering equipment, polymer system, and electrical gear.
- Removal of existing truck guides, odor exhaust system, and process piping.
- Building improvements, such as, HVAC and plumbing will not be added to this facility.

## 5.20 SITE WORK AND PIPING

### 5.20.1 General

Site work for Phase I includes construction of new facilities, demolition of existing facilities, construction of additional roadways for site access into and around the plant site, construction of an additional 26 space parking area for staff, routing of new piping, rerouting of existing piping, construction of fencing on north side of site, and tree mitigation. Significant clearing, grubbing, excavation, and grading also are required for the construction of new facilities and general site preparation. Refer to Section 6.3 for the proposed site layout.

### 5.20.2 Facility and Piping Additions

New site facilities consist of:

- Septage Receiving Station
- Influent Pump Station
- Headworks
- IPS Control Building
- Relocated Odor Control Unit
- Anoxic/Aeration Basin
- Plant Drain Pump Station #3
- Blower and Dewatering Building
- Central Power Distribution/Generators/Transformers

Refer to Section 6 for proposed site plan and site access roadway locations. See Section 5.32 for existing facilities demolition and decommissioning.

Major site piping additions consist of:

- 36-in. RWW force main from RRR to IPS
- 30-in. RWW pumped line from IPS to Headworks

- 42-in. RWW gravity line from Headworks to Aeration Basins
- 42-in. MXL from Aeration Basins to clarifier splitter box.
- 18-in. RWW line from Headworks to EQ and from EQ back to IPS
- 20-in. to 30-in. RAS from Existing Anoxic Basins to new Anoxic/Aeration Basins
- 30-in. Air line from Blower and Dewatering Building to new Anoxic/Aeration Basins

### 5.20.3 Tree Mitigation

The Mount Pleasant Code of Ordinances (MPCO) categorizes trees subject to the removal and replacement guidelines by the diameter at breast height (DBH) measurement. These categories are as follows:

- Protected Tree – Tree with a DBH equal to or greater than 8 inches. Smaller trees subject to other certain conditions in the MPCO.
- Significant Tree – Tree with a DBH of 16 inches or larger.
- Historic Tree – Tree with a DBH equal to or greater than 24 inches, with exemptions for specific species and cases.

When considering the removal of protected, significant or historic trees at the RRRWWTP, consideration should be given to criteria necessary to gain approval from the Zoning Administrator to remove the trees. Seamon Whiteside has performed tree surveys on the plant site and the additional properties that have recently been obtained by MPW. In addition to their aforementioned services, a certified arborist from Seamon Whiteside has graded the health and condition of the trees. Seamon Whiteside has identified the trees to be removed, and will develop a tree replacement schedule. The schedule includes the location, species and size of trees to be removed as well as the proposed replacement trees. In situations where tree replacement is not feasible, the Zoning Administration has the option of accepting a \$550 per four inch caliper fee for each tree that would otherwise be replaced on the site.

### 5.21 ODOR CONTROL

Odor control will be provided for the influent pump station, influent pump station screen, and headworks. It is anticipated that the existing biofilter system will be relocated adjacent to the new headworks location. The existing odor control unit will be evaluated for use at these facilities based on manufacturer recommendation for air flowrate and hydrogen sulfide removal. The existing odor control unit was sampled for gas phase hydrogen sulfide with an Odallogger on the influent and effluent side. The results of the hydrogen sulfide sampling showed that there was a peak influent hydrogen sulfide level of 51 ppm and peak effluent hydrogen sulfide level of 0.4PPM over a three day period in the month of December 2016. The raw influent wastewater was sampled and tested for dissolved sulfides. The result of the sample evaluation concluded a sulfide level of 4 mg/l based on a 24 hour composite sample completed on December 28, 2016. MPW also reported that the raw influent has a pH of 7.33.

The existing Biorem BASYS 44X packaged biofilter system will be relocated near the new headworks. The existing steel vessel, media, exhaust fan, fan motor, VFD, and control panel will be reused. Additional media (1,100 cubic feet) will be added to increase the system capacity to 5,800 scfm while maintaining an empty bed residence time of 30 seconds. New instrumentation/gauges, water supply piping and valving, and air ducting will be provided, and the unit will be placed on a new concrete slab above the 100-year flood elevation shown in the latest (preliminary) FEMA flood map.

The existing control panel will be connected to the plant's updated SCADA system and will send two simple signals: "RUN" and "COMMON ALARM." The system will be manually controlled using the local control panel, and all instrumentation will be manually read, to match the existing configuration.

The headspace air at both the influent pump station and headworks structure will be tightly sealed, with only a small hole provided in each cover to allow in makeup air. Ducting will be connected to each headspace air chamber, and odorous air ducting routed back to the biofilter system for treatment. At least 12 AC/hr will be provided for all headspace areas, with the first chamber at the Influent Pump Station receiving 23 AC/hr of ventilation due to the increased H<sub>2</sub>S concentrations expected in this chamber. During the transition period when the existing system is being relocated, a temporary odor control system will be connected to the existing headworks to prevent fugitive odor emissions from the site.

## 5.22 INSTRUMENTATION AND CONTROL

The network architecture implemented at RRRWWTP is employed throughout the utility. Currently, it is not intended that the architecture be changed as part of the improvements at the plant. However, some changes to the configuration of the existing switches will be needed to implement improvements to the fiber-optic network.

The segmented fiber-optic network at the RRRWWTP will be expanded to include new PLCs that are installed as part of the improvements implemented as part of this rehabilitation/expansion. This expansion will be implemented via new segments to new Enterasys fiber-optic switches located in the new PLC panels in a configuration that will result in a true redundant path fiber-optic network utilizing the rapid spanning tree protocol.

Substantial improvements are to be implemented to the Human Machine Interface (HMI) system including redundant I/O servers, a high-availability Historian and additional operator interface workstations strategically located throughout the plant.

The planned process improvements require additional instrumentation throughout the plant to facilitate the increased level of control and monitoring of the different processes at the facility. This instrumentation will provide process information to the controllers and operators which will allow for increased efficiencies in the consumption of power and chemicals while maintaining the plant operating parameters within those required by the regulating authorities.

## 5.23 POWER DISTRIBUTION

As part of the Phase 1 upgrades major improvements to the electrical distribution system will be implemented. A new 480V main switchboard will be arranged in a Main-Tie-Generator arrangement, with the ability to accept main power from the utility step down transformers and a standby generator feed. Preliminary calculations indicate the transformer will be sized for 2,000kVA, however all electrical infrastructure will be designed and installed to support increased transformer size to 2,500kVA under future improvement projects. In addition to the main switchboard a generator paralleling switchgear will be provided and will support the connection of two generators, with a breaker for a future third generator, including controls for paralleling the generator sets. This generator will connect to the generator side main beaker of the main switchboard and will allow for standby power to be delivered to any point on site without the installation of Automatic Transfer Switches.

The main switchboard will deliver 480V power to two main-tie-main switchboards, one located in existing Control Building 1 and one in the new Aeration Building, as well as the new Influent Pump Station/Headworks MCC. The Control Building 1 switchboard will provide power to the Effluent Pump VFDs, the existing Lab Building, the existing Dewatering Building, and a new MCC installed in existing Control Building 1. The Aeration Building Switchboard will provide power to the new Aeration Blowers, existing MCC-13 and MCC-14 in existing Control Building 2, and a new MCC in the Aeration Building.

## 5.24 STANDBY POWER

Standby power at the plant is currently provided by two 900kW standby generators, which were installed between 10 and 15 years ago. Based upon preliminary calculations these generators can provide enough power to supply nearly all of the loads required to maintain treatment under design flow conditions for the 9.2 MGD expansion. These existing generators are intended to be re-used for the new project. The generators will be relocated to a new common standby generator equipment pad. Both generators would be connected to the generator paralleling switchgear, from which point standby generator power could be distributed throughout the plant.

Based upon preliminary calculations the two existing generators, operating in parallel can power all required loads in most scenarios, however in a peak flow scenario some load shedding may be required to keep the plant's power consumption below the generator rating. All electrical infrastructure constructed as part of this project will be sized to accommodate replacing the 900kW generators with new 1,500kW generators in the future in order to meet future power demands.

## 5.25 CONTROL BUILDING ONE

Control Building One currently contains an electrical room which houses much of the plants electrical equipment, including the main service entrance switchboard. The following is a list of major equipment housed in this electrical room:

- 8SWBD-1 (Main Service Switchboard)
- Aerator Motor Control Center
- 8-MCC3

- 8-MCC4
- 8-SWBD2
- VFD MCC-12
- Effluent Pump VFDs
- Automatic Transfer Switches for various MCCs
- Miscellaneous Power and Lighting Panels

Upon completion of this Phase 1 upgrades this electrical room will be re-used to house electrical equipment. In order to facilitate the installation of a new switchboard within this building, the new aeration basins must be completed and energized before de-energizing the existing aeration MCC. Once completed, demolition of the aeration MCC can be completed and installation of the new switchboard can be installed in place of the aeration MCC. The existing main switchboard 8-SWBD1 can then be demolished. Subsequently a new MCC will be installed in the Control Building 1 Electrical Room, which will power new loads in the proximity of the Control Building, as well as replace 8-MCC3, 8-MCC4, and VFD MCC-12. Once all new electrical panels are installed all obsolete equipment, including ATSS and miscellaneous panels will be removed.

## **5.26 CONTROL BUILDING TWO**

The Control Building 2 Electrical Room currently houses two MCCs (MCC-13 and MCC-14) and an ATS that provides power to the MCCs. This ATS currently derives power from its own SCE&G utility step down transformer, which is planned to be removed as part of the Phase 1 upgrades. The power for MCC-13 and MCC-14 will be provided from the new aeration blower switchboard and will render the utility transformer and ATS obsolete. Once power to MCC-13 and MCC-14 has been transitioned to the new Main Switchgear the utility step down transformer and ATS will be demolished. There will also be minor modifications made to MCC-13 and MCC-14 as part of the Phase 1 upgrades, but these will not significantly impact the layout of Control Building 2.

## **5.27 POWER SYSTEM STUDIES**

During the construction phase of the project the Contractor will commission a short circuit and protective device coordination study of relays, fuses, and circuit breakers. This study will cover the new portions of the power distribution system in addition to all remaining existing electrical equipment. The study will be used to establish the settings of all adjustable relays and circuit breakers, and to illustrate how all overcurrent devices coordinate with each other. The Contractor will submit for review a report documenting all information.

During the construction phase of the project the Contractor will commission an Arc Flash Hazard Analysis for each piece of new electrical equipment in addition to all remaining existing electrical equipment. The Arc Flash Hazard Analysis will be performed in association with the short circuit analysis and coordination study. The Arc Flash Hazard Analysis will determine incident energy levels at designated electrical equipment and the Personal Protective Equipment required to service the equipment. Arc flash labels will be furnished on each piece of electrical equipment as required by NFPA 70E in order to identify the hazard to plant staff.

## 5.28 LIGHTING PROTECTION, SURGE PROTECTION DEVICES AND TVSS

Provide and install surge suppressors devices on the following existing devices and circuits connected to the existing PLC in the Control Building:

- Siemens Hydro Ranger Plus Level Controller – Location; Plant Drain Pump Station
- Siemens Hydro Ranger 200 Level Controller – RAS 1 – Location: RAS Pump Station
- Siemens Hydro Ranger 200 Level Controller – Influent Well Headworks
- Gate Access Key Pad/Phone

Surge suppressors shall be added to protect both the transmitter and the control system end of the circuit. Surge protection devices shall not impede or interfere with the existing transmitter calibration/communication. The Owner requests that surge suppressor devices be manufactured by the same manufacturer as what is already being provided for the new analog circuits.

For the existing Siemens switchboard provide TVS4EMA24A SPD unit (or equal) in a separate enclosure above switchboard as near to the feeder breaker as practical. Install a new 30A circuit breaker (confirm breaker size with SPD manufacturer) in existing space within switchboard to feed the new SPD unit. Install 3#10,#10G in ¾-in. conduit between switchboard and new SPD unit, minimizing circuit length to the extent practical.

For the existing VFD MCC-12 install an integrally mounted SPD unit, MCC4IMA24 (or equal) in existing free space within the MCC enclosure. This unit is a complete unit with integral breaker, so no additional work should be required. Contractor shall provide a new blank cover plate for the existing space in MCC section in which SPD is being installed.

## 5.29 REUSE PLANT SERVICE WATER

The existing reuse water and the existing plant service water systems are to be combined into a new pump system that will provide water for existing demands as well as the water demands for new plant equipment and wash-down stations.

The existing reuse water system is a factory built and packaged variable speed water boost pump system. The existing system consists of three 10 hp vertical multistage centrifugal pumps with integrated variable frequency drive motors. Each pump has a maximum capacity of 125 gpm at 180 psi. The existing reuse water system is located adjacent to the chlorine contact basins and it provides reuse water to the administration building and the Sloan Park ball fields.

The existing plant service water system consists of two vertical turbine pumps, an automatic strainer and ancillary valves and instruments. The plant service water system is located in the northeastern corner of the chlorine contact basin and it provides water to plant equipment. Each vertical turbine pump is rated for 230 gpm at 184 feet.

The new combined plant water system will provide water to the plant, the administrative building and the Sloan Park ball fields and it will be located in place of the existing plant service pumps at the northeastern corner of the chlorine contact basin. The new plant service water system will consist of three VFD-driven vertical turbine pumps, two duty and one standby. The duty pumps are

sized for the demands listed in the Plant Service Water Demands table below which include anticipated demands for a future belt filter press and a future clarifier.

The pump system includes an automatic strainer, a magnetic flow meter, a recirculation valve and an expansion tank. Sodium hypochlorite will be injected downstream of the automatic strainer and the flow meter. A check valve will be provided between the sodium hypochlorite injection location and the flow meter to ensure that sodium hypochlorite never backs into the pumps, the strainer or the flow meter. The plant water system will be controlled by varying pump speed to maintain a discharge pressure. The recirculation line will recirculate excess water back to the chlorine contact basin if the plant service water demand is less than the minimum turndown of one pump. The expansion tank will hold system pressure when the pumps are off.

The primary water demands (excluding hose bibbs and hydrants) are listed in the table below.

**Table 5-25 Plant Service Water Demands**

LOCATION	ITEM	CAPACITY (GPM)	PRESSURE (PSI)
Headworks	Grit Pumps	75	40-60
Headworks	Center Flow band Screen	31	60
Headworks	Washer/Compactor Screen	4	60
Headworks	Center Flow band Screen	31	60
Headworks	Washer/Compactor Screen	4	60
Clarifier #1	Spray Nozzles	25	7
Clarifier #2	Spray Nozzles	25	7
Clarifier #3	Spray Nozzles	25	7
Clarifier #4 (Future)	Spray Nozzles	~25	~7
EQ Tanks	Water Cannons	400	100
Dewatering	Belt Filter Press #1	75	90
Dewatering	Belt Filter Press #2	75	90
Dewatering (Future)	Belt Filter Press #2	~75	~90
Admin Building	Chiller	250	60
Sloan Park Ballfields	Irrigation	180	60

The plant water system design criteria are summarized in the table below.

**Table 5-26 Plant Service Water Pumps**

DESCRIPTION	DESIGN CRITERIA
Pump Type	Vertical Turbine
Manufacturers	Sulzer, Flowserve, Xylem, Goulds
Configuration	2 duty + 1 standby



DESCRIPTION	DESIGN CRITERIA
Total Dynamic Head (TDH), ft	185
Rated Capacity, each, gpm	650
Firm Capacity, gpm	1,300
Motor Size, hp	50
Speed, rpm	1,800
Drive Type	VFD
Control	Discharge Pressure (70-80 psig @ system discharge)
Expansion Tank Capacity, gal	~200
Recirculation Valve Setpoint, psig	90 psig

## 5.30 PLANT DRAIN PUMPING SYSTEM

### 5.30.1 Plant Drain Pump Station #1

Plant Drain Pump Station #1 currently houses two ABS submersible vortex pumps. These pumps have a rated performance of 450 gpm @ 45 TDH. The pump station currently receives flow through sewer gravity mains from residential areas south and west of the plant site and also from process and sewer drains within the plant site, including: the existing headworks, existing septage receiving station, laboratory building, control building, chlorine contact, secondary clarifiers, effluent pump station, chlorination building, and existing dewatering building.

As part of Phase I upgrades, piping to and from the existing headworks and from the existing septage receiving station will be demolished and capped. New 8-in. piping will be routed from the new Chlorine Contact Basins to Plant Drain Pump Station #1. New 8-in. piping will be routed across the plant site to the new influent pump station location (approximately 700 feet of piping). Based on the rated capacities of the existing pump shown in the table below and due to no increases in influent flows at Plant Drain Pump Station 1, the existing plant drain pumping is adequate to pump to the new IPS/Headworks location.

**Table 5-27 Plant Drain Pump Station #1**

DESCRIPTION	DESIGN CRITERIA
Quantity	2 Pumps, One Duty and One Standby
Rated capacity of existing pumps	450 gpm, each pump, @ 45 ft TDH
Static Head (New IPS and PDPS #1)	18 ft
Piping and Fitting Losses (New IPS and PDPS #1)	8.9 ft
TDH required to pump to new IPS location	~27 ft



### 5.30.2 Plant Drain Pump Station #2

Plant Drain Pump Station #2 currently houses two submersible chopper pumps. These pumps have a rated capacity of 525 gpm @ 50 feet TDH. The pump station currently receives flow from existing Sludge Storage Tanks #1 and #2 and the sediment dewatering container.

Proposed modifications for Phase I plant upgrades include:

- Routing drain and decant from new Sludge Storage Tank #3 to PDPS #2.
- Tie new 6-in mixed liquor scum piping from Aeration Basins into the existing 6-in. plant drain line from Sludge Storage Tanks #1 and #2 at existing blind flange located in the yard.
- Combine the contents of PDPS #2 and PDPS #3 through their respective force mains and tie into the 30-in RAS piping that returns flow to the Anoxic Mixing Chimney.

The existing pumping capacity of Plant Drain Pump Station #2 is adequate as long as the decanting operations from the existing and new Sludge Storage Tanks are not performed simultaneously. If this is the case, further pumping upgrades will be needed.

### 5.30.3 Plant Drain Pump Station #3

Plant Drain Pump Station #3 is a new pump station being designed to receive filtrate, wash water, and condensate from the two air compressors from the new Blower and Dewatering Building. The decision has been made to construct a new pump station because Plant Drain Pump Station #2 is approaching its maximum available capacity and negative process effects can result from mixing sludge and filtrate. The pump station wetwell will be precast construction and the top will be set at approximate at-grade elevation of 9.00ft-NAVD88.

Plant Drain Pump Station #3 will pump its contents through a 12-in force main; combine with the force main from Plant Drain Pump Station #2 to further combine with the 30-in RAS piping. The 30-in RAS piping will carry its contents along with the contents from Plant Drain Pump Station #2 and #3 to the Anoxic Distribution Structure.

**Table 5-28 Plant Drain Pump Station #3**

DESCRIPTION	DESIGN CRITERIA
Quantity	3 Pumps, Two Duty and One Standby
Rated capacity of pumps	632 gpm, each pump, @ 34 ft TDH
Max Static Head (Anoxic Distribution Structure)	28 ft
Piping and Fitting Losses (Anoxic Distribution Structure)	4.5 ft
TDH required to pump to new Anoxic Distribution Structure	34 ft
Wetwell diameter	10 ft
Wetwell depth	14.6 ft

### 5.30.4 Existing Dewatering Building Pump Station

The existing Dewatering Building Pump Station is currently designed to receive flow from the existing Sludge Dewatering Building and pump to the existing Anoxic Selector Basins through a 6-in. force main. As part of Phase I plant upgrades, the existing Anoxic Selector Basins are being converted to Sludge Storage Tank #3 and the existing Dewatering Building will be converted to a new Operations Building. Therefore, the existing Dewatering Building Pump Station will be decommissioned and abandoned in place. Also, the force main piping from the existing Dewatering Building Pump Station will be capped and abandoned in place.

## 5.31 EFFLUENT FORCE MAIN RESTRAINT

### 5.31.1 General Background

It has been determined that the existing buried 90 degree bends of the effluent force main are not provided with concrete thrust blocks and pipe joints are not restrained as required by the 1991 CH2M-HILL contract documents.

### 5.31.2 Options to Mitigate Unrestrained Pipeline Joints

B&V is tasked with developing a piping restraint plan to investigate and restrain the required length of force main at the Effluent Pump Station for 120 psi test pressure, which is the equivalent restraint requirement of the existing effluent force main. This plan will allow MPW to make the proper decision on how to mitigate the potential risks associated with the findings of the restraint evaluation of the existing effluent force main. The piping restraint plan is as follows:

The existing effluent force main shall remain in operation (pressure of XXX) while Contractor installs joint and fitting restraints. Contractor shall install restraints (per Spec XXXXX) on all straight pipe joints. Contractor shall uncover one joint at a time and install restraint joints. Following the restraint of all pipe joints, Contractor shall restrain pipe fittings. Contractor shall investigate fittings as they are uncovered to determine if they are mechanical fittings or bell and spigot. If fittings are mechanical, Contractor shall install restraints (per Spec XXXXX). If fittings are not mechanical, Contractor shall install concrete thrust blocks (per drawing or detail or spec). Contractor shall also provide temporary restraint on pipe fittings as they are uncovered until proper restraint is installed.

## 5.32 EXISTING FACILITIES DEMOLITION AND DECOMMISSIONING

This section covers the demolition of existing structures, piping, equipment, and salvage of existing equipment as indicated here.

### 5.32.1 Structure Demolition

The following structures at the RRRWWTP shall be demolished, and the debris shall be removed from the jobsite or partial structural modifications shall occur. Existing piping to these facilities will be rerouted to new facilities, abandoned in place, or demolished.

**Table 5-29 Structure Demolition**

<b>ENTIRE</b>	
Headworks	New Headworks constructed at North end of site.
Existing Generator Structure/Pad	Located east of existing blower building
<b>PARTIAL</b>	
Existing Aeration Basins #1 & #2	Curved interior baffle walls, mechanical piping, pumps, and aerators are being removed for the conversion of Wet Weather Tank #1 and Future Wet Weather Tank #2
Anoxic Selector Basins	Select interior walls are being removed and some mechanical piping
Odor Control	Demolition of existing foundation.
Control Building	All interior toilet/utility room space is being removed for electrical improvements.

As Phase I design progresses, this list will be re-evaluated and additional structures and/or equipment may be added.

## 6.0 Supplemental Memoranda

## 6.1 LIQUID PROCESS FLOW DIAGRAM

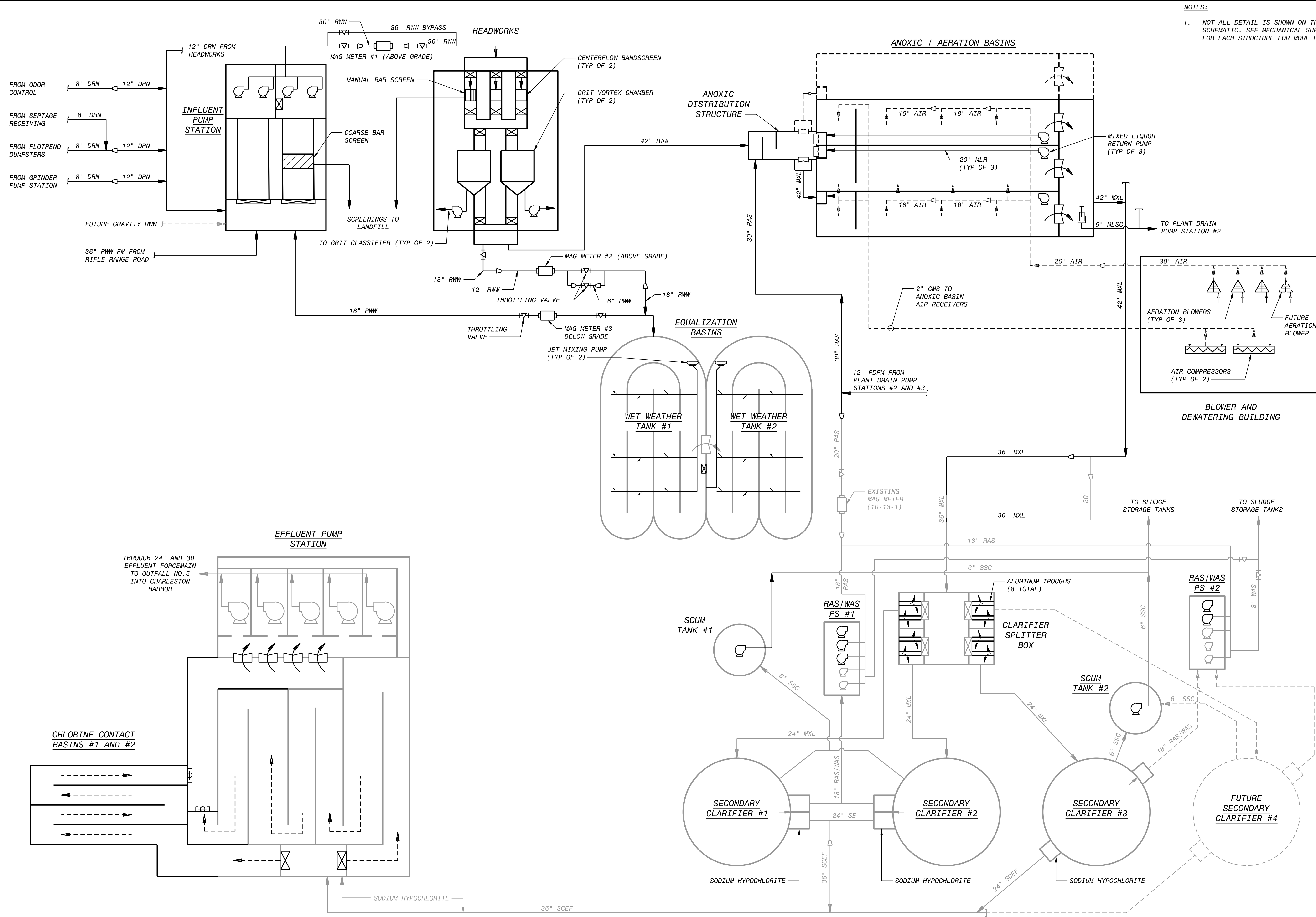

NOTES:  
 1. NOT ALL DETAIL IS SHOWN ON THIS SCHEMATIC. SEE MECHANICAL SHEETS FOR EACH STRUCTURE FOR MORE DETAIL.

DATE	REVISIONS AND RECORD OF ISSUE	NO.	BY	APP.
50.3010	General Drawings			
	G-000-006.dwg			
	SAVED: VAN16643, 9/20/2017 10:33:01 AM			
	PLOTTED: VAN16643, 9/21/2017 11:09:16 AM			
	USER: VAN16643			
	DWG. VER: 1000			



**MOUNT PLEASANT WATERWORKS  
 RIFLE RANGE ROAD WWTTP  
 REHABILITATION AND EXPANSION PROJECT**

**GENERAL  
 LIQUID PROCESS FLOW DIAGRAM**

DESIGNED: C. MILLER  
 DETAILED: V. VANATTA  
 CHECKED:  
 APPROVED:  
 DATE: OCTOBER 2017

0 1/2 1  
 IF THIS BAR DOES NOT MEASURE 1" THEN DRAWING IS NOT TO FULL SCALE

PROJECT NO.  
 192352

**G-000-006**  
 SHEET  
 OF

**PRELIMINARY - NOT FOR CONSTRUCTION**

ED7800\_PW  
 D7800

## 6.2 SOLIDS PROCESS FLOW DIAGRAM

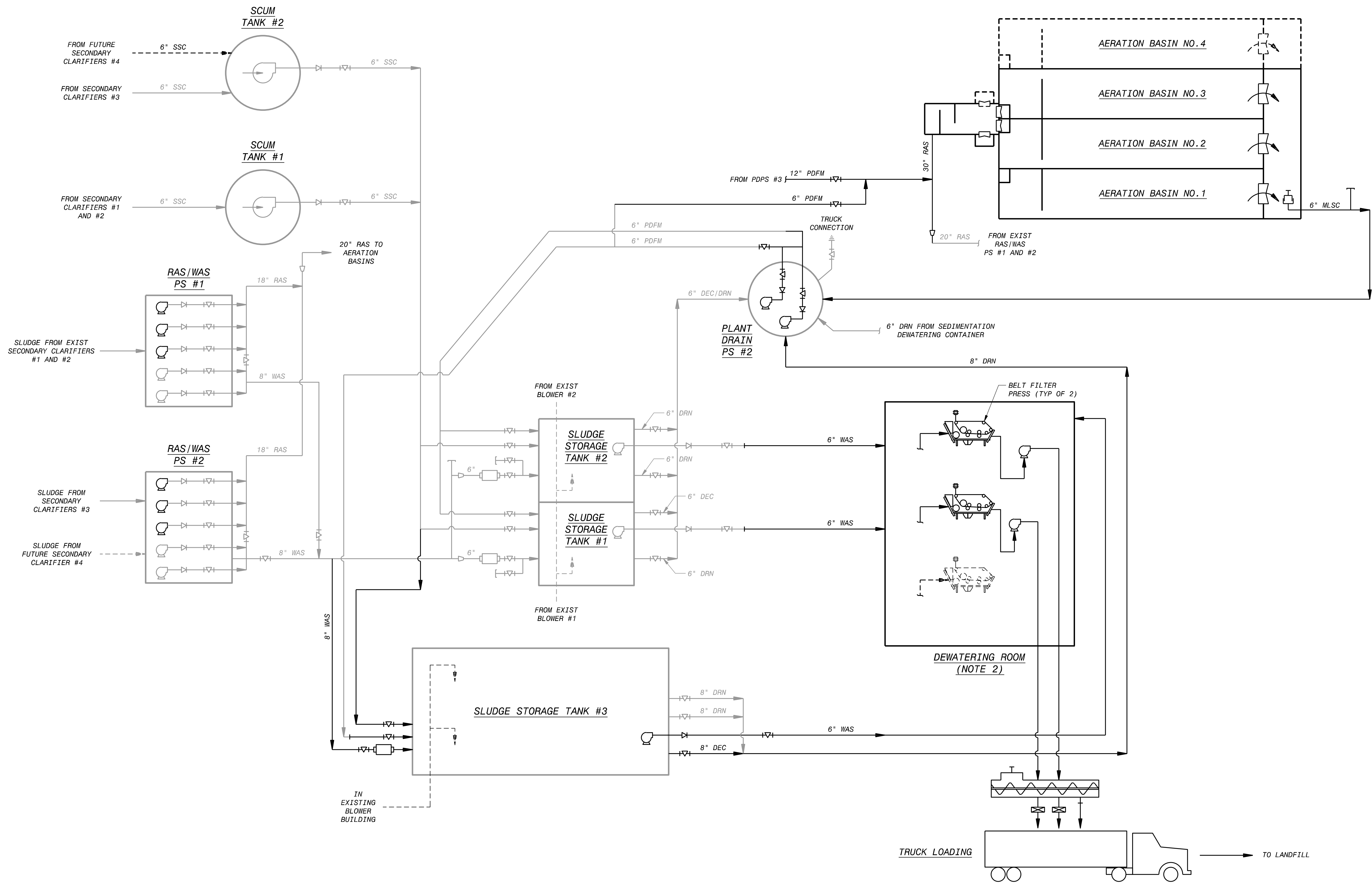

**NOTES:**

1. NOT ALL DETAIL IS SHOWN ON THIS SCHEMATIC. SEE MECHANICAL SHEETS FOR EACH STRUCTURE FOR MORE DETAIL.
2. SEE MECHANICAL SHEETS FOR SLUDGE FEED PIPE AND ARRANGEMENT TO BFP-1 AND BFP-2 (AND FUTURE BFP-3)

DATE	REVISIONS AND RECORD OF ISSUE	NO.	BY	APP.
50.3010	General Drawings			
	G-000-007.dwg			
	SAVED: VAN16643_9/18/2017 11:51:33 AM			
	PLOTTED: VAN16643_9/21/2017 11:10:27 AM			
	USER: VAN16643			
	DWG. VER: 1000			



**MOUNT PLEASANT WATERWORKS  
 RIFLE RANGE ROAD WWTP  
 REHABILITATION AND EXPANSION PROJECT  
 GENERAL  
 SOLIDS PROCESS FLOW DIAGRAM**

DESIGNED: B. VANLANDINGHAM  
 DETAILED: V. VANATTA  
 CHECKED:  
 APPROVED:  
 DATE: OCTOBER 2017

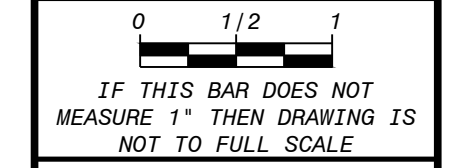

PROJECT NO.  
**192352**  
 SHEET  
 OF

**PRELIMINARY - NOT FOR CONSTRUCTION**

E:\19000\_PW  
 D:\000



### 6.3 PROJECT DRAWINGS

SHEET C-001-122

SHEET C-001-123

GENERAL NOTES:

- 1. SEE DRAWING G-00-005 FOR ADDITIONAL GENERAL NOTES.
- 2. SEE PARTIAL PLANS AND SPECIFICATION SECTION 01015 FOR EXISTING EFFLUENT FORCEMAIN INVESTIGATION AND RESTRAINT PLAN.
- 3. REFER TO SECTION 15067 FOR PLANT SERVICE WATER PIPE 3 INCH AND SMALL.

DATE	REVISIONS AND RECORD OF ISSUE	NO.	BY	APP.
90.3010	General Drawings			
	CY101.dwg			
	SAVED:R0331473_11/11/2017 3:49:23 PM			
	PLOTTED:R0331473_11/11/2017 3:46:46 PM			
	USER:R0331473			
	DWG VER:1001			

SHEET C-001-121

SHEET C-001-126

SHEET C-001-124

SHEET C-001-128

SHEET C-001-127



Black & Veatch Corporation  
Civil/Environmental/Infrastructure

**MOUNT PLEASANT WATERWORKS  
RIFLE RANGE ROAD WWTP  
REHABILITATION AND EXPANSION PROJECT**

**SITEWORK  
OVERALL YARD PIPING PLAN**

DESIGNED: SDD  
 DETAILED: SMW, KTH  
 CHECKED:  
 APPROVED:  
 DATE: OCTOBER 2017

0 1/2 1  
 IF THIS BAR DOES NOT  
 MEASURE 1" THEN DRAWING IS  
 NOT TO FULL SCALE

PROJECT NO.  
 192352

**C-001-120**  
 SHEET  
 OF

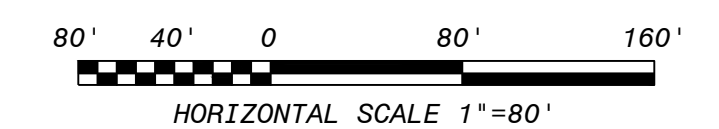

PRELIMINARY - NOT FOR CONSTRUCTION

5/27/00  
D7006

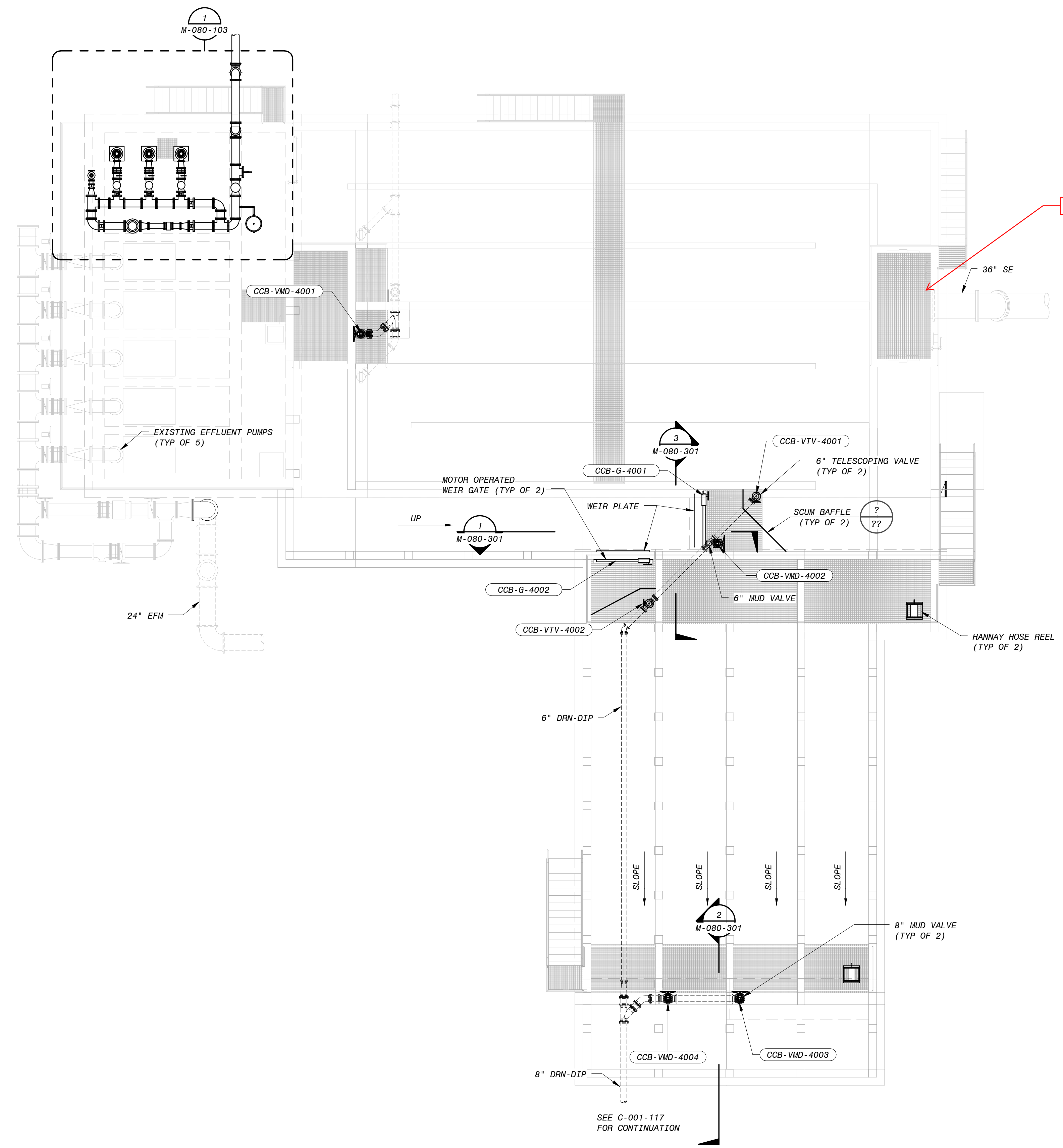

NOTES:  
 1. THE EXISTING FACILITY IS TAKEN FROM RECORD DRAWINGS. CONTRACTOR SHALL VERIFY DIMENSIONS.

FLASH MIXER

MODIFIED PLAN  
 1/8" = 1'-0"

PRELIMINARY - NOT FOR CONSTRUCTION

PLOTTED: 9/22/2017 9:02:48 AM

	NO. _____ BY _____ DATE _____ REVISIONS AND RECORD OF USE
<b>BLACK &amp; VEATCH</b> Black & Veatch Corporation Charleston, South Carolina	
<b>MOUNT PLEASANT WATERWORKS</b> RIFLE RANGE ROAD WWTTP REHABILITATION AND EXPANSION PROJECT MECHANICAL CHLORINE CONTACT BASINS OVERALL PLAN	
DESIGNED: R. ECK DETAILED: B. STRICKLIN CHECKED: Checker APPROVED: Approver DATE: OCTOBER 2017	
IF THIS BAR DOES NOT MEASURE 1" THEN DRAWING IS NOT TO FULL SCALE	
PROJECT NO. 192352	
<b>M-080-102</b> SHEET OF XXX	





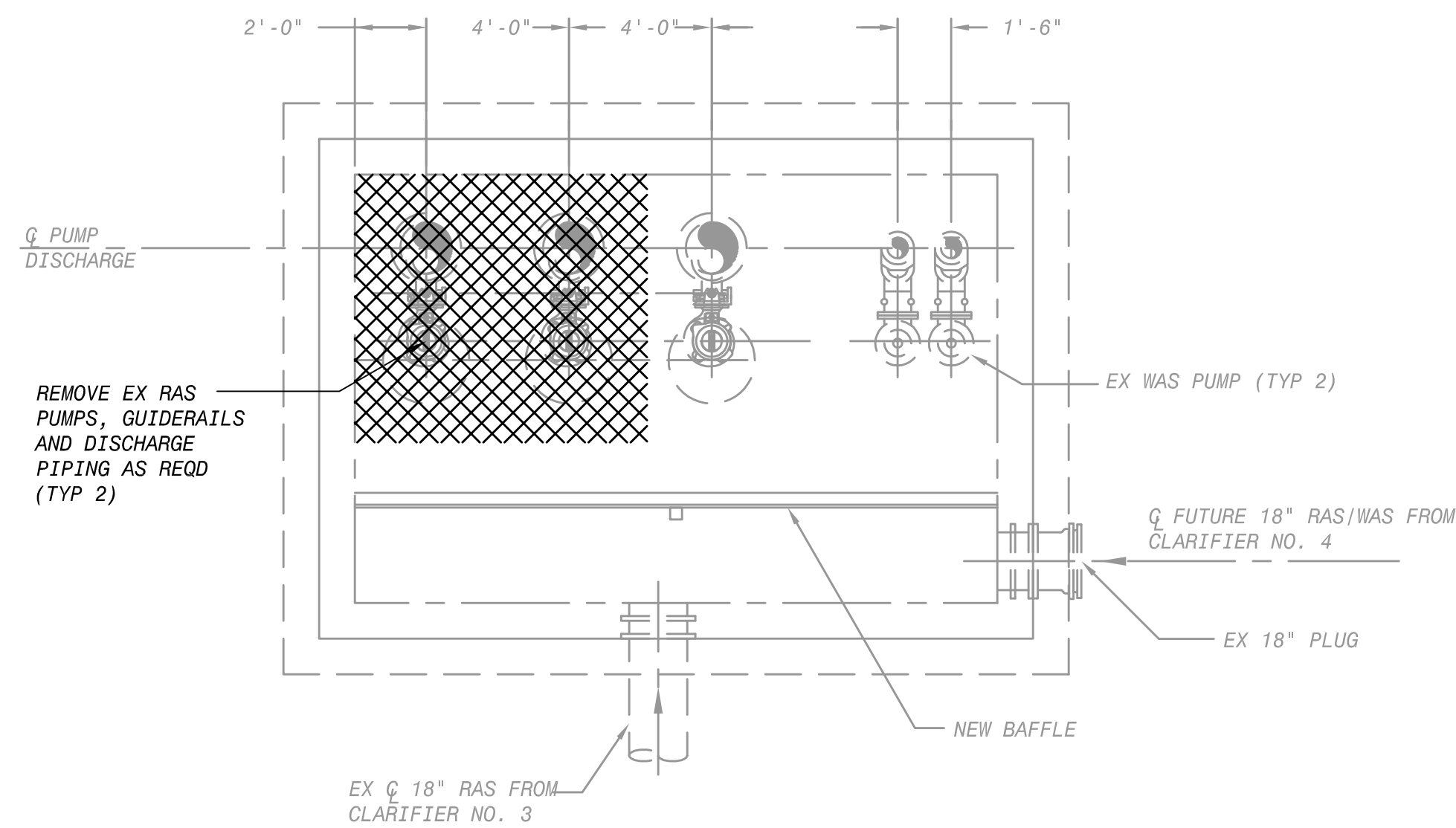
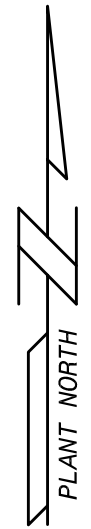

**DEMOLITION - LOWER PLAN**

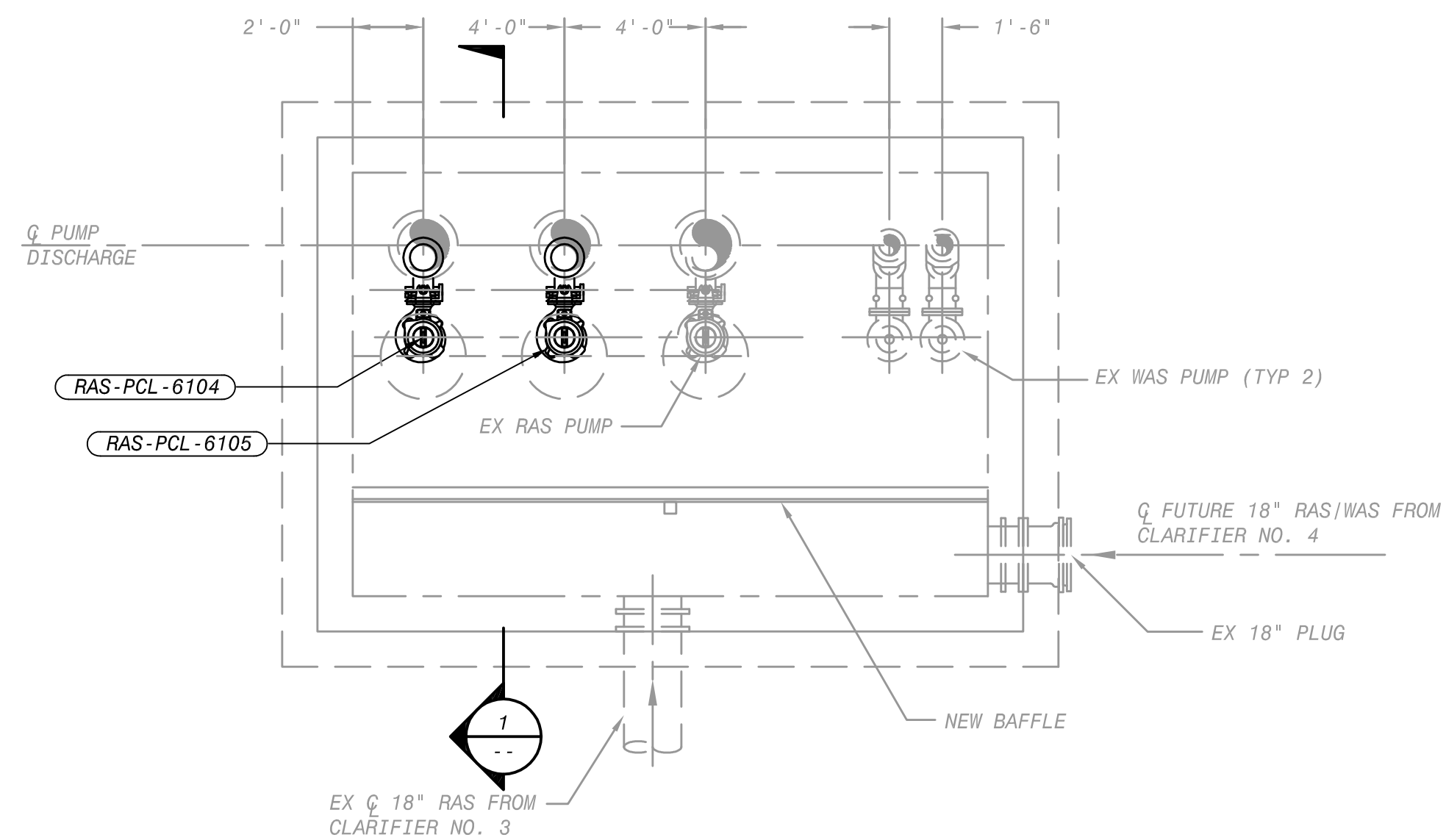

**LOWER PLAN**

RAS/WAS PUMPING STATION NO. 2 OPERATING LEVEL ELEVATIONS	
HIGH LEVEL ALARM	9.50
LAG RAS PUMP START	9.00
LEAD RAS PUMP START	8.00
LAG RAS PUMP STOP	7.00
LEAD RAS PUMP & WAS PUMP STOP	5.50
LOW LEVEL ALARM	2.00

**DEMOLITION LEGEND**

- DEMOLISH AND DISPOSE
- ABANDON IN-PLACE
- REMOVE AND SALVAGE
- REMOVE AND RELOCATE

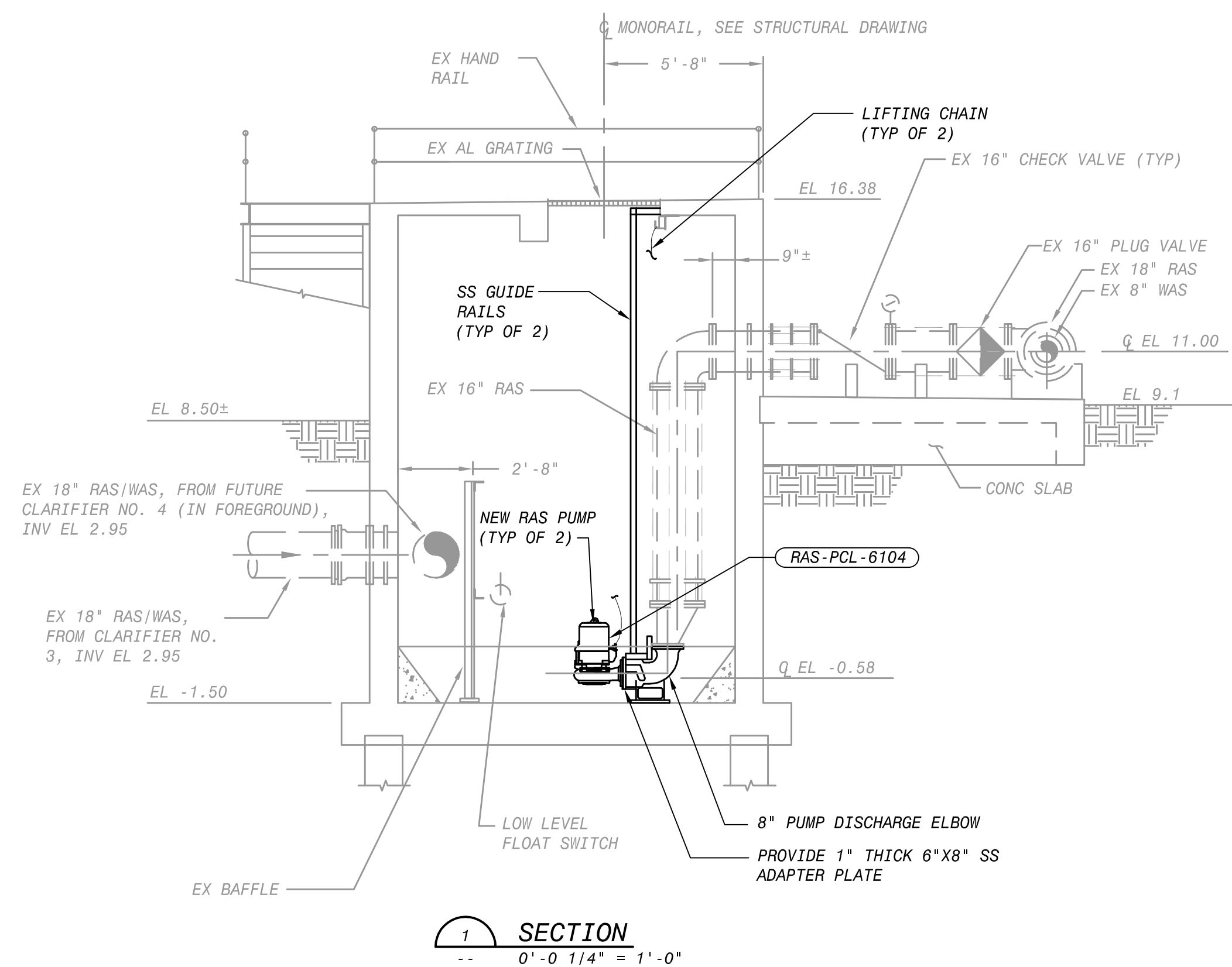

**SECTION**  
0'-0 1/4" = 1'-0"

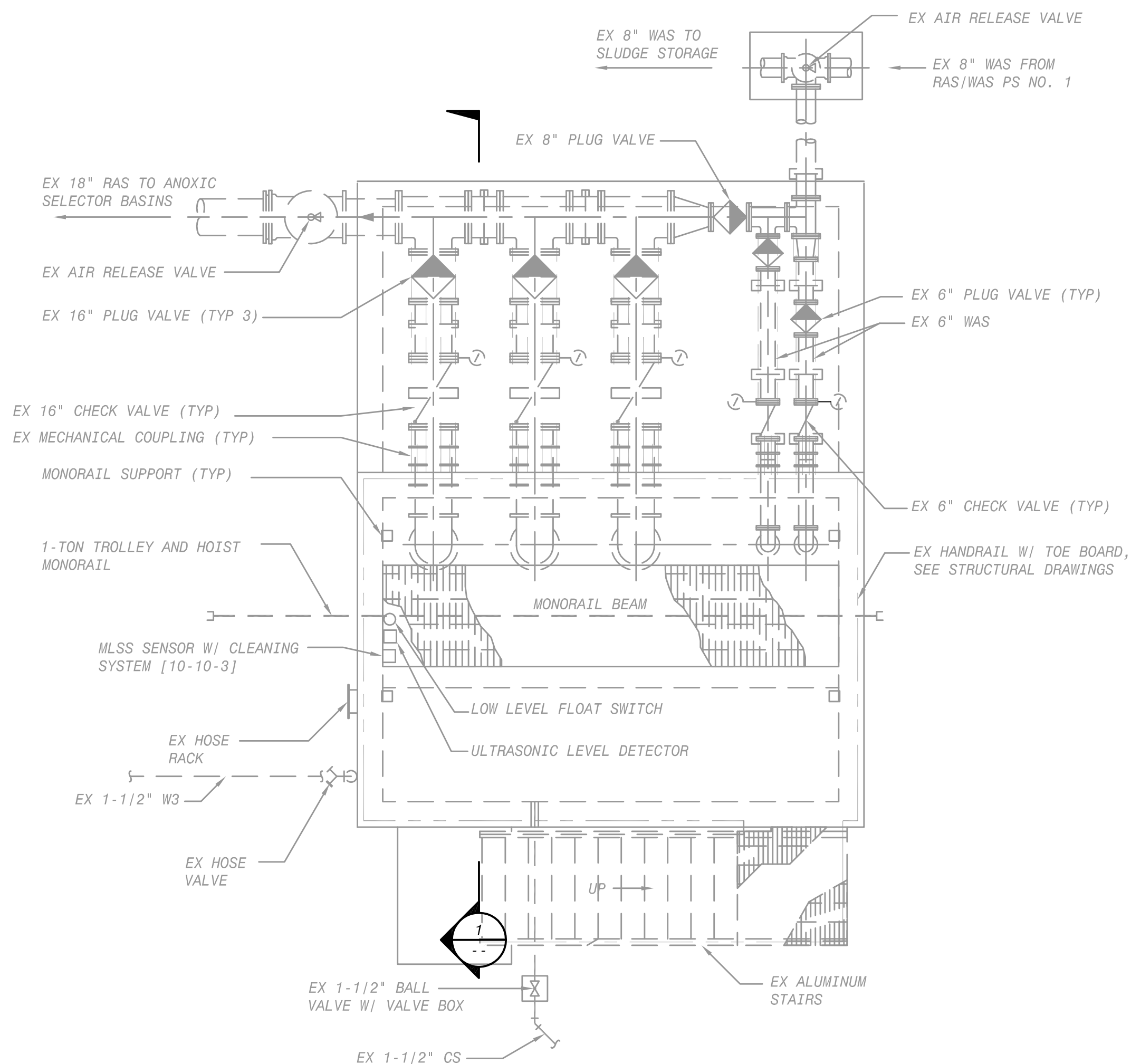

**UPPER PLAN**

**NOTES:**

- REFER TO SPECIFICATION SECTION 11150, SUBMERSIBLE PUMPS FOR ADDITIONAL INSTALLATION REQUIREMENTS.

**BLACK & VEATCH**

Black & Veatch Corporation  
Charleston, South Carolina

**MOUNT PLEASANT WATERWORKS  
RIFLE RANGE ROAD WWTP  
REHABILITATION AND EXPANSION PROJECT**

**MECHANICAL  
EXISTING RAS/WAS PUMPING STATION 2  
PLANS, SECTION AND DETAIL**

DESIGNED: B. MARTIN  
 DETAILED: B. STRICKLIN  
 CHECKED:  
 APPROVED:  
 DATE: OCTOBER 2017

0 1/2 1  
 IF THIS BAR DOES NOT  
 MEASURE 1" THEN DRAWING IS  
 NOT TO FULL SCALE

PROJECT NO.  
192352



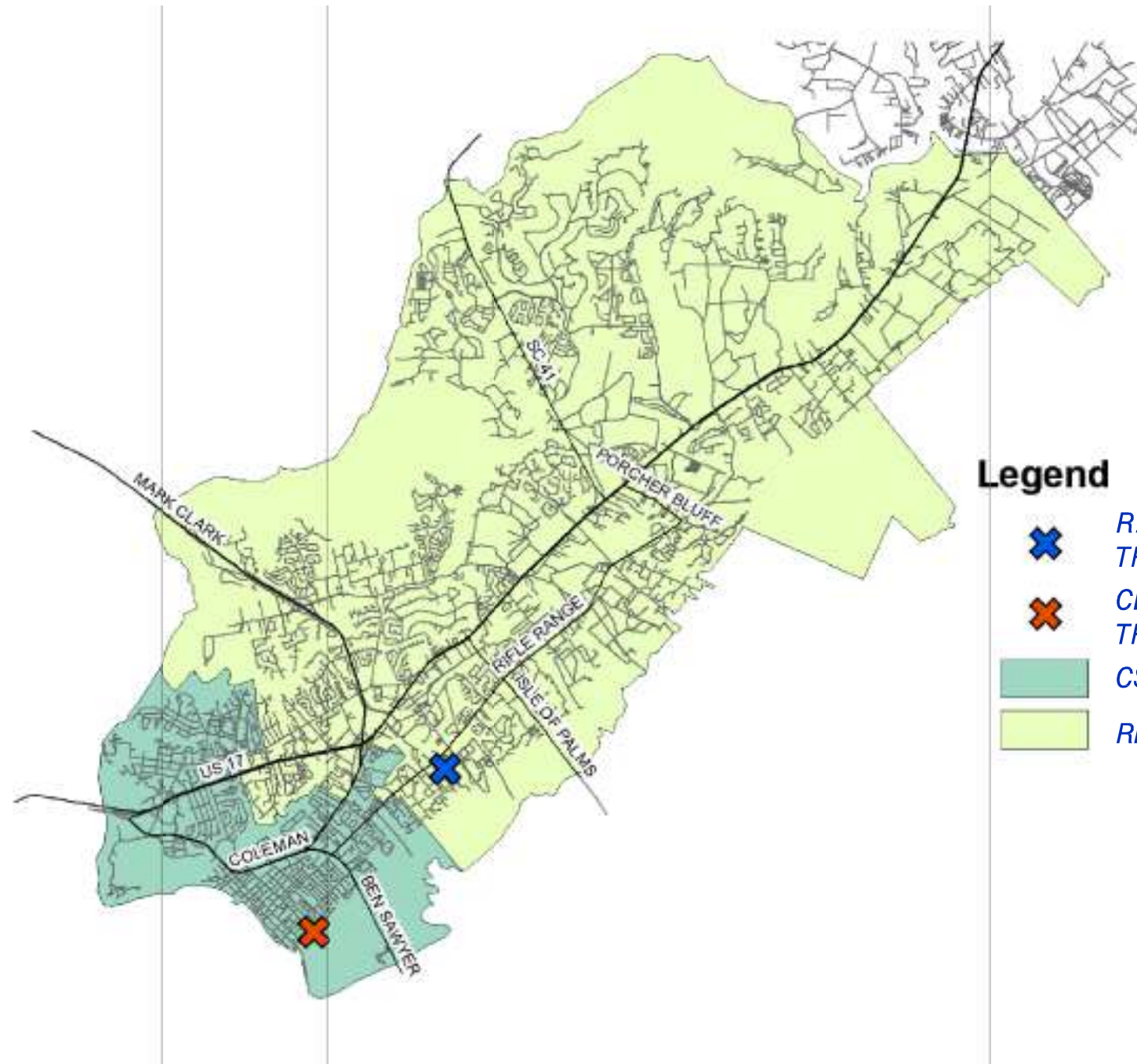

**M-105-101**  
SHEET  
OF

**PRELIMINARY - NOT FOR CONSTRUCTION**

## 6.4 MPW SERVICE AREA MAP



**Legend**

-  RIFLE RANGE ROAD WASTEWATER TREATMENT PLANT (RRRWTP)
-  CENTER STREET WASTEWATER TREATMENT PLANT (CSWTP)
-  CSWTP SERVICE AREA
-  RRRWTP SERVICE AREA

## 6.5 EFFLUENT DISCHARGE FORCEMAIN MAP





# Mount Pleasant Waterworks Rifle Range Road Wastewater Treatment Plant Effluent Discharge Forcemain



Mount Pleasant Waterworks	July 2009
Effluent Discharge Force Main	Appendix B

## 6.6 UNITED STATES GEOLOGICAL SURVEY (USGS) MAP FOR DISCHARGE OUTFALL



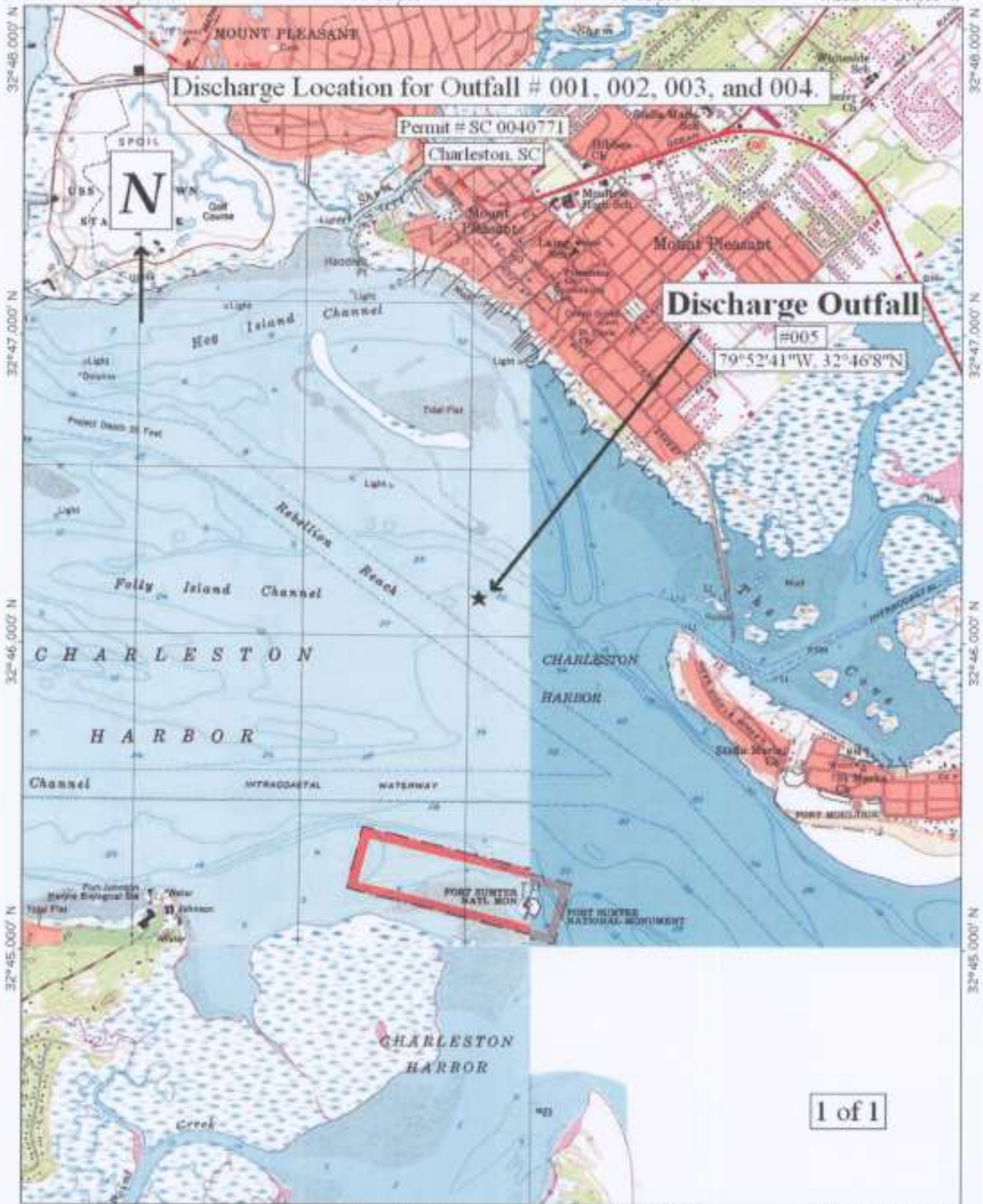

Discharge Location for Outfall # 001, 002, 003, and 004.

Permit # SC 0040771

Charleston, SC

Discharge Outfall

#005

79°52'41"W 32°46'8"N



1 of 1



## 6.7 RRRWWTP ONE MILE RADIUS TOPOGRAPHIC MAP



# Rifle Range Road Wastewater Treatment Plant One Mile Radius - USGS Quad Maps

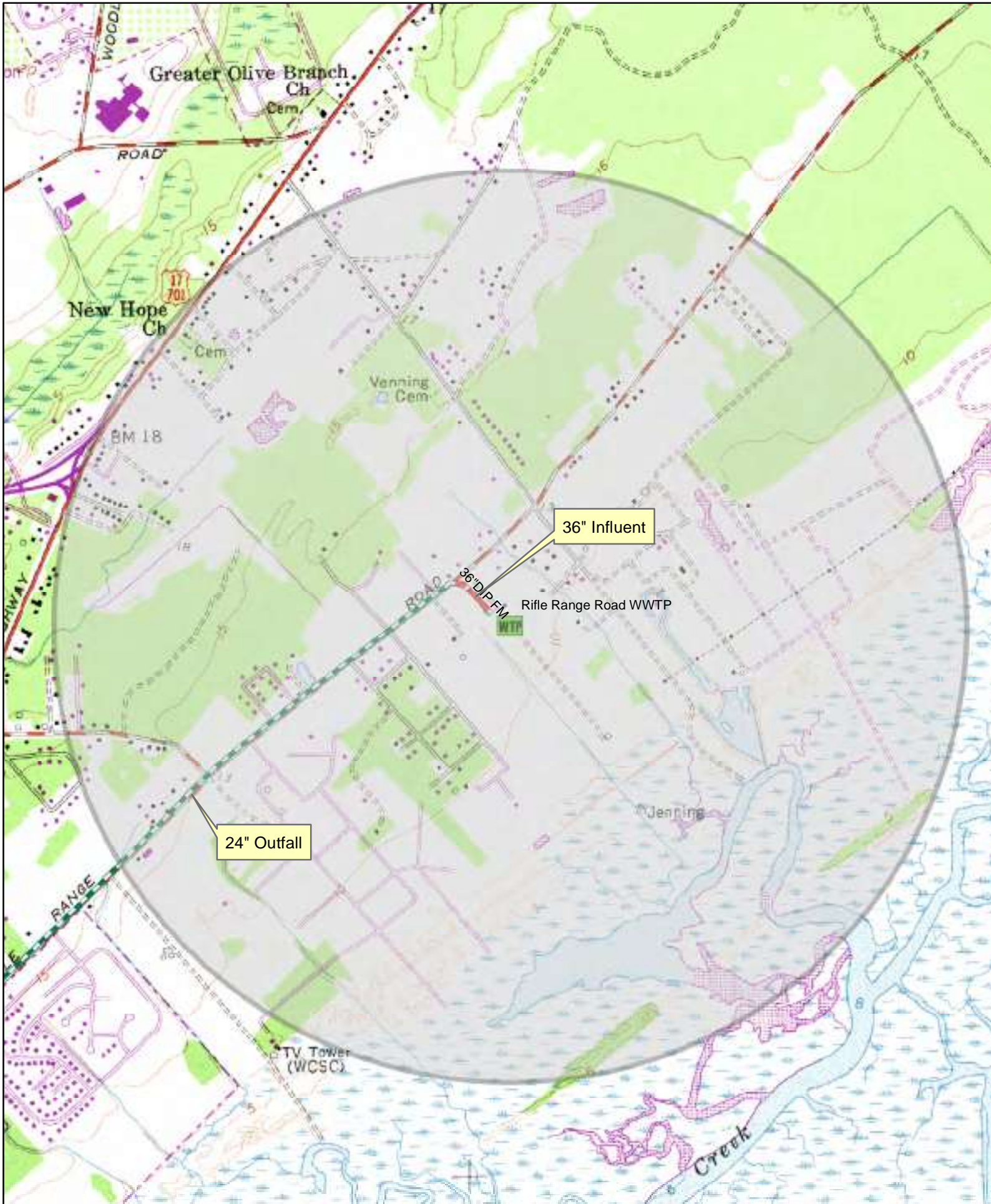



## 6.8 MPW 20-YEAR LAND PLANNING AREA MAP

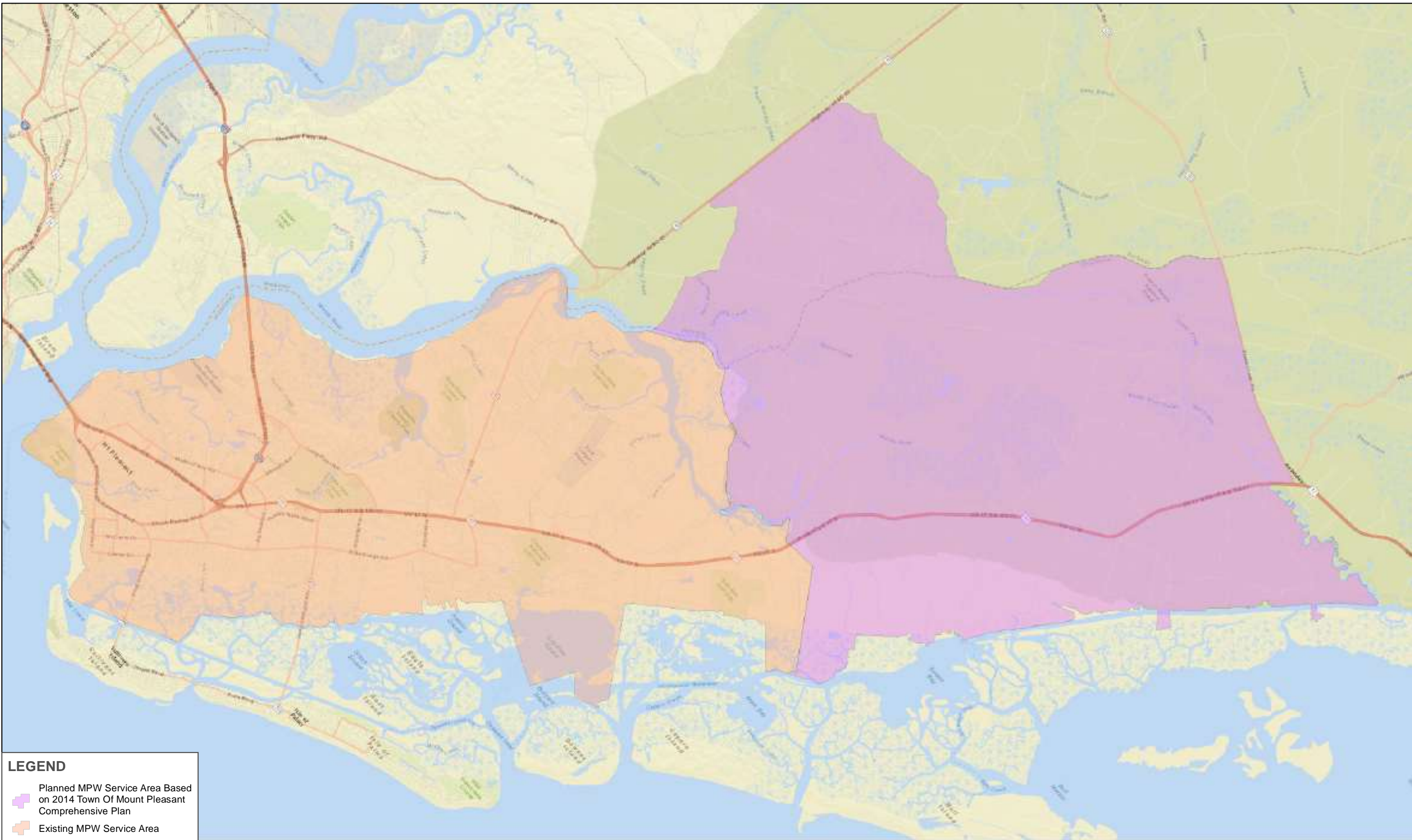



**LEGEND**

-  Planned MPW Service Area Based on 2014 Town Of Mount Pleasant Comprehensive Plan
-  Existing MPW Service Area



Existing and Planned Service Areas  
MPW Comprehensive Utility Master Plan



## 6.9 MPW 20-YEAR LAND USE MAP



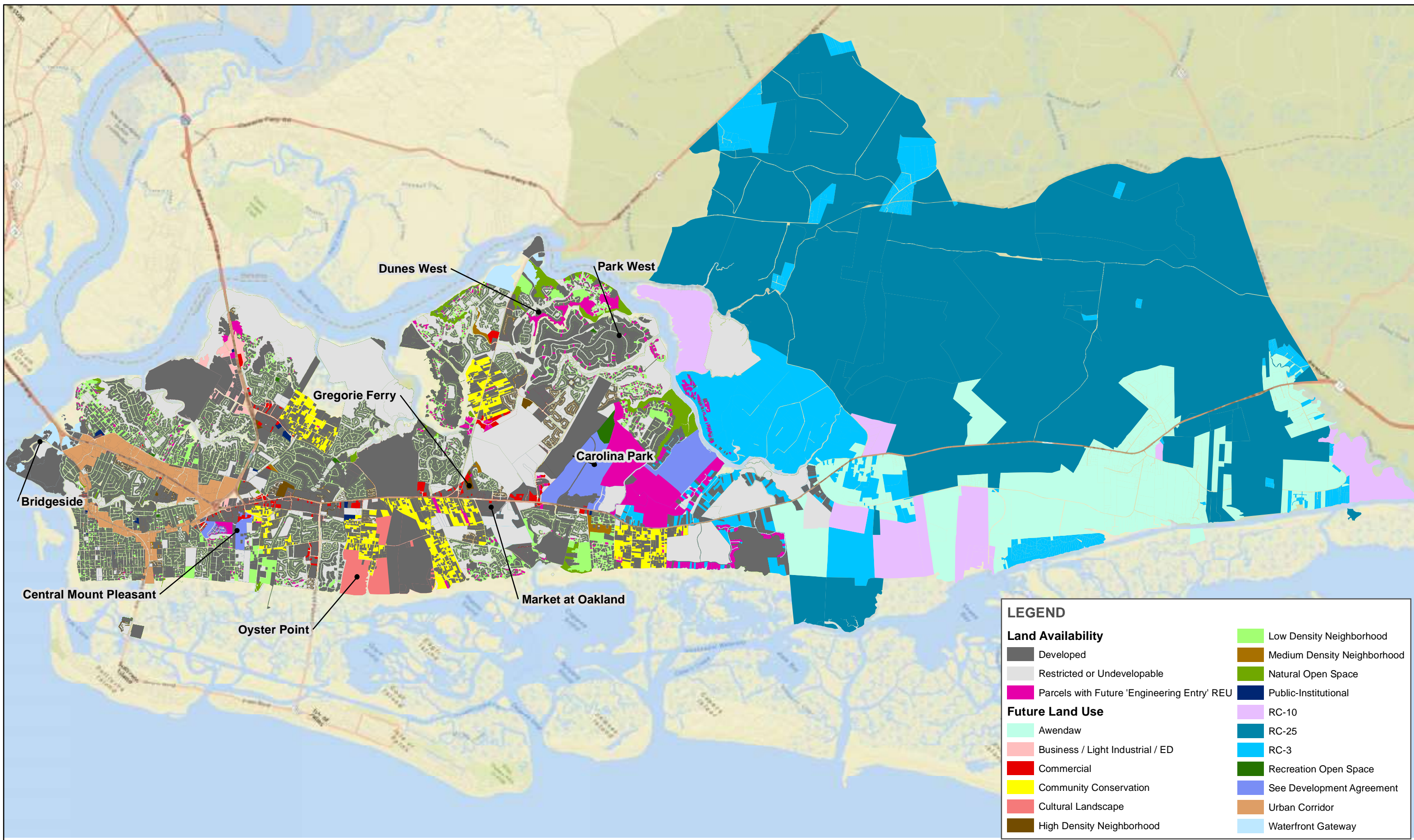

Future Land Use and Land Availability  
MPW Comprehensive Utility Master Plan



Figure 6  
CDM Smith

## 6.10 MPW 20-YEAR POPULATION GROWTH PROJECTIONS

# Growth Projections

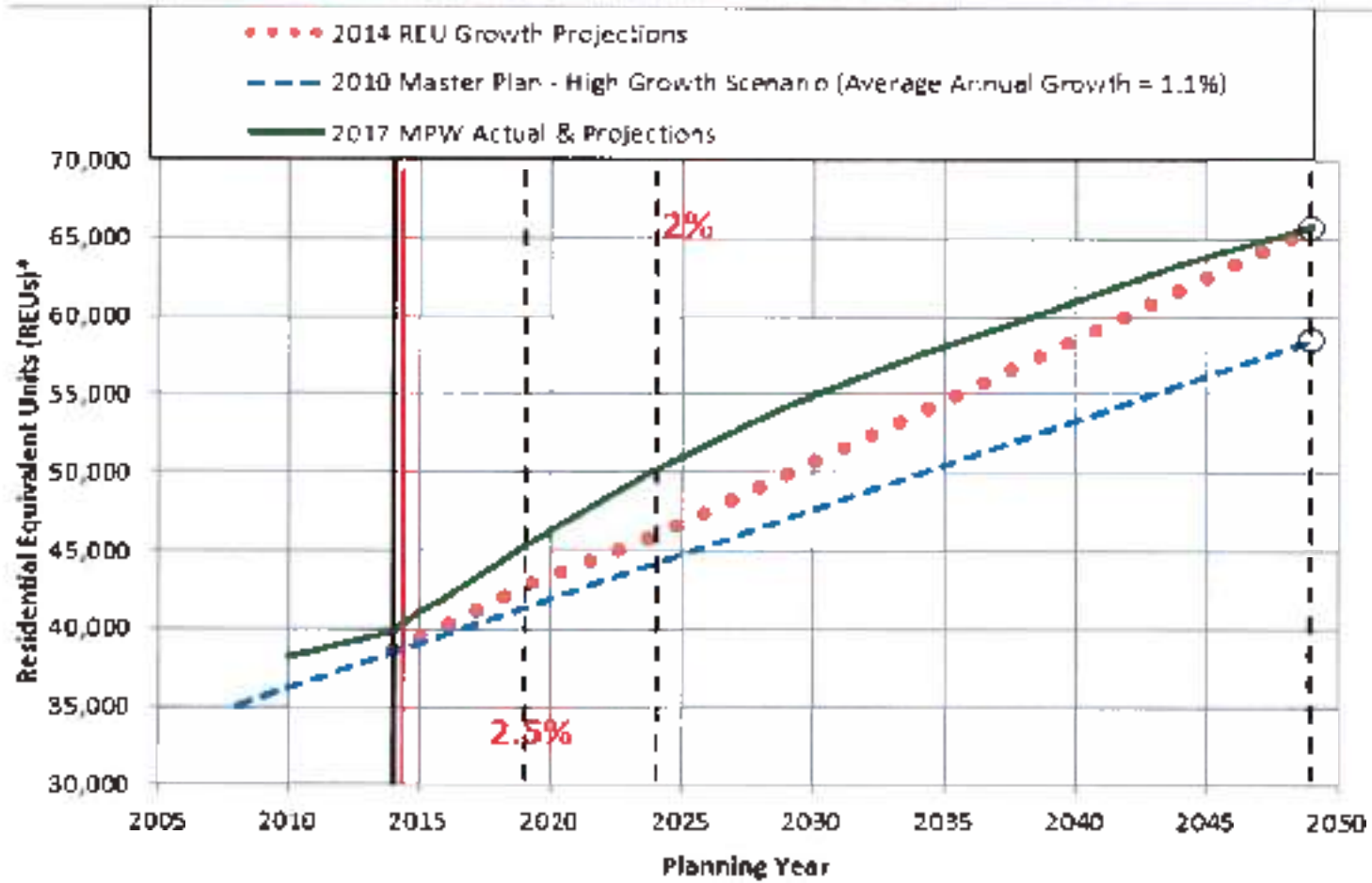

## 6.11 MPW 20-YEAR FLOW PROJECTIONS

20-year Flow Projections

